

# THE BEST OF TIME DESIGNS VOLUME ONE

time  
DESIGNS™  
MAGAZINE

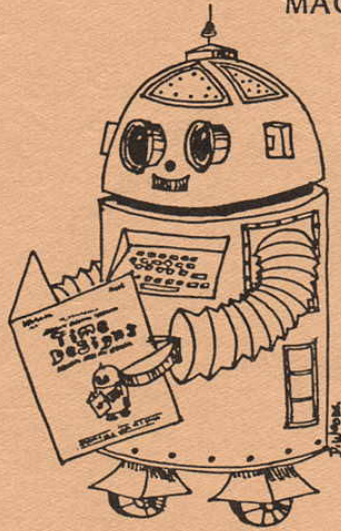

FOR ALL TIMEX AND SINCLAIR COMPUTERS

**TIMEX** **sinclair**

# THE BEST OF TIME DESIGNS VOLUME ONE

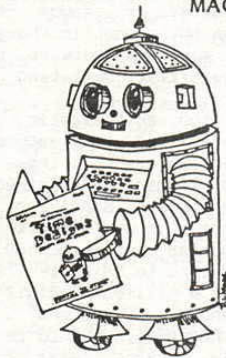

TIME DESIGNS MAGAZINE is published bi-monthly and is Copyright © 1986 by the **Time Designs Magazine Company**, Colton, Oregon 97017. All rights reserved.

**Editor:** Tim Woods

**Assistant Editor:** Stephanie Woods

**Editorial Assistant/Production:** D.L. Woods

**Photography:**

(unless otherwise noted): Thomas Judd  
Printing by; Toad'I Litho Printing and Comp.,  
Oregon City, Oregon 97045

Reproduction of this magazine in whole or in part by any means without written permission is prohibited by law

**"NOTICE:** Contributors to TIME DESIGNS are independent of the TIME DESIGNS MAGAZINE CO., and opinions expressed in the contents of the magazine are not necessarily those of the management or its advertisers. Time Designs Magazine Co. will not be held liable for any damage or consequences resulting from instructions, assertions of fact, review of products or companies provided in the magazine's content."

**TIME DESIGNS MAGAZINE CO.**  
29722 Hult Rd. • Colton, Oregon 97017

## contents

Rise And Fall Of The Timex Computer Corp.....	2
Why Time Ran Out For Timex.....	2
Micro Muse.....	6
Introduction To Computer Control.....	6
Automatically Set RAMTOP.....	9
"Boxes".....	11
A Monitor Adapter For The T/S 1500.....	12
DATA/READ On A T/S 1000.....	13
Adventures In The RAM Jungle.....	15
New Products For The T/S 1000	
8k ROM Upgrade.....	17
BSOS.....	18
Software Reviews	
BASLOAD.....	19
Supertape.....	19
"PABLO PIXEL-O".....	20
A Graphics Problem For The 2068.....	27
2068 Graphics: More or Less.....	29
"3D Tunnel".....	30
Machine Code Joystick Routine.....	31
"2068 Color Demo".....	32
"Slot Machine".....	33
"Joystick Demo".....	34
"Alphabetizer".....	34
"Tic Tac Toe".....	35
"Pie Chart".....	35
"House Payments".....	35
Entering/Recalling Text In Machine Code.....	36
Screen Display Storage And Memory Relocate.....	37
Make A Static Discharge Bracelet.....	38
Breaking And Saving 2068 Programs.....	40
VAMP TV To Monitor Kit.....	41
TASWORD TWO Tips.....	41
Bookshelf Review: Manual For Dot Matrix Printers	42
ROMSWITCH.....	42
Z-LINK.....	44
OMNI-EMU.....	45
Spectrum Software	
White Lightning.....	46
The Lords Of Midnight.....	48
Braxx Bluff.....	49
Deus Ex Machina.....	49
Pyjamarama.....	50
Sherlock.....	51
SoftAid.....	52
American Football.....	52
Aerco FD-68 Disc Drive System.....	53
Disc Drive Repair Tip.....	54
Damco/Rotronics Wafadrive.....	55
Zebra Graphics Tablet.....	57
Zebra Talker.....	58
2068 Software Reviews	
ZIP BASIC Compiler.....	59
Coupon Magic.....	61
Dealer's Den.....	61
PRO/FILE 2068.....	62
2068 Grade Book.....	63
Night Gunner.....	63
Great Game And Graphics Show.....	64
National TS Users Group Directory.....	65
Timex/Sinclair Resource Guide.....	68



# THE RISE AND FALL OF THE TIMEX COMPUTER CORP., WHERE DO WE GO FROM HERE?... AND SEVERAL OTHER OBSERVATIONS BY THE EDITOR



I don't know exactly what came to your mind when you heard the news on February 22, 1984, but as for myself, I was bitterly disappointed. Although, my total investment in this computer "hobby" wasn't that great, it was the fact that the Timex Computer Corporation had made some strong promises on hardware and software support for my machine. To hear that they were dropping their computer line in the U.S. was just a little too hard to swallow. It left some big questions to be answered. Would products still be available? How about repair service? What would happen to the 100 or so Timex Sinclair user clubs. Would mail-order houses and magazines stick it out?

Over a year before, I had discovered my first Sinclair computer. The little device proved to be surprisingly powerful, and it wasn't long before I had been bitten by the Sinclair bug. Due to the low cost of the TS line, many units had been sold, and it was very evident that there were a lot of fellow aficionado's who shared the same interests and concerns.

The whole story goes back to some years ago, when an extremely bright British "tinkerer", also head of a modest radio electronics company, designed and developed (along with his engineering team), the world's first inexpensive personal microcomputer...the ZX80. It was available as both an experimenter's kit or a fully assembled model. The inventor, Clive Sinclair, was later knighted by her majesty, Queen Elizabeth, for his contribution to the advancement of British technology--thus the proper name--Sir Clive Sinclair...and fondly nicknamed "Uncle Clive" by followers world-wide. It is said that Sir Clive was the single-most factor that made England the most computer-literate country in the world.

The ZX80, was shortly replaced by the ZX81, with an improved ROM and more memory. The Timex Corporation, was a sub-contractor, and was manufacturing the ZX81 for Sinclair in a Timex-owned factory in Scotland, for the

European market. Through this early partnership, most certainly brought Sinclair's computer technology to the U.S. The celebrated ZX81 took on the form of the Timex Sinclair 1000. Although the original ZX had been available in the states on a small mail order scale from Sinclair's U.S. office, it didn't equal the large distribution by Timex. The TS 1000, with it's flat membrane keyboard, low resolution black and white screen display and 2K RAM (the ZX81 had only 1K RAM), was the first computer in America to sell for less than \$100. It was to be found in almost every discount house and drug store, essentially, wherever a Timex watch might be sold. Not every pharmacist or department store clerk was prepared to demonstrate or answer computer-related questions to a curious buying public though. Thus began the start of a rocky marriage between the affordable home computer, and the bizzare marketing techniques of Timex.

However, it was the enthusiastic Timex Sinclair owners that somehow prevailed. Many support groups and user clubs were formed. Buyers of these "new-fangled" little computers were pleasantly surprised at the very powerful capabilities of the Sinclairs despite their cheap packaging and price. A whole new industry grew up overnight--small companies that produced hardware and software support, catering to TS users via mail order. Within two years, over a million Sinclair machines were sold in the states, and nearly two and a half million worldwide. Although they never reached the sales level or popularity of Apple, Atari, Texas Instruments, or Commodore in the U.S., Sinclair maintained the number one sales spot in Europe, outselling the other brands by 50%.

1983 was a disaster in the home computer market, forcing the giant Texas Instruments to drop their 994/A model. Too much competition and price cuts also affected the Timex Computer Corporation...as the TS 1000 (a

## Why time ran out for Timex's home computer

The New York Times

Three decades ago, Timex Corp. made its name by turning wristwatches into commodities, selling inexpensive, reliable timepieces in thousands of drugstores and discount outlets across the country.

Wednesday, industry analysts said the same strategy effectively killed the company's chances in the home computer market. And the company's traditional secretiveness, they added, greatly slowed the efforts of outside parties to design computer programs and equipment.

That assessment came a day after Timex announced that, like Texas Instruments and Mattel Inc. before it, it was abandoning its efforts to sell the most inexpensive computers after concluding that it could not sell the machines profitably.

As it bowed out, Timex was estimated to have sold more than one million units of the British-designed Sinclair computer, largely to customers that had never before purchased an electronic device more complicated than a calculator.

"Buying a computer is not like buying a watch, and they fundamentally did not understand that," said Kirtland H. Olson, publisher of Syntax, a monthly newsletter for owners of the Timex Sinclair line of computers. "People need support when they buy a computer. When Timex got that message, they had already taken a serious licking."

Just two years ago, when Timex brought out the Timex Sinclair 1000, the company looked like it was on the brink of a great success. The computer, while limited in memory power, was the first to sell in the United States for under \$100. Moreover, Timex's broad distribution network, including drugstores, retail discounters and catalog stores, appeared to give the company a marked lead over less established competitors.

But in the past couple of years, consumers have grown accustomed to buying computer equipment in outlets that can provide them with information as well as additional components and programs.

Wednesday, an official of the privately held company denied that Timex's failure was due to any strategic errors, but cited the rapid changes in the home computer market in 1983.

C.M. Jacobi, Timex's vice president for marketing and sales, said Wednesday at even in light of the industry's price war last year, "I don't think we would have done much differently."

He continued: "Our users were very complimentary of the machine. It is just that the industry built inventory faster than it should have, and then had to liquidate them at very low prices. We did not think things would go as far as they did."

Harold Kinne, senior vice president of Future Computing Inc., called the Timex machine "a computer

literacy device" that was overtaken by more sophisticated computers made by Atari, Texas Instruments and Commodore.

Users of Timex equipment were more critical. Some said Wednesday that they did not believe the machine was a joy -- a reputation it got within the industry because Timex failed to release more sophisticated models until late last year, when the Timex Sinclair 1000 was already overtaken by computers offering better games and graphics. But, they added, Timex took little interest in nurturing its users.

Sinclair has said it would market its new \$500 computer itself.

Martin Newman, a Manhattan musician who owns two Timex computers, said Timex "always had a nasty attitude." He added, "When you called to ask any technical questions, their attitude was 'too damn bad.'"

Similar problems were encountered by the estimated 400 companies that sell programs and peripheral equipment such as disk drives for Timex computers. Timex "turned away the help," Olson said.

That secretiveness appears rooted in Timex tradition. The company was founded in the 1940s by T. Frederick Olsen, a Norwegian who owns a majority of the company's stock and has rarely granted interviews.

victim of more advanced computer models and brands) had nearly slipped into the shadows by that Christmas. A local record store near where I live sold brand new ones in the box for a mere \$10! One thing was for certain--Timex had to do something...and quick. Many dealers and consumers were demanding something new.

Indeed, Timex did have somewhat of a success with the 1000, but had been hinting about an "all new" line of computers with more advanced features. Several other major manufacturers were upgrading their lines. Even Sinclair Research headed by Sir Clive, had developed a new color computer called the ZX Spectrum (available in either a 16k and 48k model).

Just as the TS 1000 was an offspring of the ZX81, the new Timex model 2068 was based on the Sinclair ZX Spectrum design. It was originally entitled the TS 2000, and was to be more or less a stock Spectrum with a Timex label, but when the computer miserably failed the FCC's radio interference certification testing, a model which was to be a future Spectrum upgrade, was readied for production. Like it's cousin the Spectrum, it was available in two RAM versions (the proposed 2048 and 2072). A last minute corporation decision scrapped the lesser version and went for one single model...today's TS 2068. The 2068 improved Spectrum technology by providing a better keyboard, a programmable Sound chip, twin joystick ports, bank-switching capabilities, advanced video modes, and a ROM-based cartridge dock. A few weeks before Christmas of 1983, the first batch of new 2068's were shipped. The timing for the important Holiday season was a big disappointment...but Timex did deliver the new computer almost six months ahead of its original planned release date. The pressure from eagerly awaiting distributors expedited the shipment.

For unknown reasons, another computer model was also briefly marketed--the TS 1500. It was for all practical purposes an upgraded TS 1000, with the optional 16k RAM Pack built in, a pushbutton keyboard and packaging similar to the Sinclair Spectrum, and with a suggested retail price of \$80.

With the new 2068 and all of the planned add-on expansion devices, it appeared that the Timex Computer Corporation was back on the right track again. There were published accounts of problems in management and relations with the public and the so called third-party after-market vendors. Some individuals frequently spoke of Timex's frustrating "closed-door" policies. But in early 1984, culminating with a rumored management change it appeared that this situation was finally mending.

The rest is history, when in February, the vice president of marketing and sales for Timex, C.M. Jacobi, gave the announcement: "We believe instability in the home computer market will cause the value of inventories to decline, making it difficult to make a reasonable profit. Further, we are concerned that those conditions will strain trade relations between manufacturers and retailers, a relationship which Timex Corporation values very highly. These factors, coupled with strong demand in our other product lines, have indicated that Timex can now better utilize it's resources in those areas." Jacobi later added, "Consequently Timex has decided to withdraw from the retail portion of the home computer business. The company will continue as a manufacturer and parts supplier to several large companies in the computer industry." Another Timex spokesman told Time Designs Magazine that, "We believed that our 1500 and 2068 computers represented fine value for both the consumer and the retailer, but our overall analysis of the business led us to the conclusion that 1984 would be another year of turmoil in the market place, making it difficult to make a reasonable profit." When asked about computer repairs, the spokesman replied, "Factory repair and service will continue more or less indefinitely...at this time, there are no immediate plans to discontinue this program."

The records show that 1984 became a stabilizing year for the home computer market. Cut backs were made, belts tightened, but it wasn't the disaster that Timex officials predicted. Most experts agree that their conservative outlook caused them to jump ship a little premature. Although the TS 1000 had been panned by the critics as a "toy", a "high-tech doorstop" and a "pregnant calculator", Timex had a real winner with the 2068. Several favorable reviews appeared in magazines like FAMILY COMPUTING and INFO WORLD, just about the time Timex bailed out. In it's short lived three month existence, over 150,000 2068's were sold.

The Research and Development division of Timex had several interesting items planned for the 2068. Some of the peripherals were released simultaneously with the 2068 such as the TS 2020 Data Cassette Recorder, the TS 2090 Joysticks, and of course the TS 2040 printer was just as compatible with the 2068 as it was the 1500 and 1000. Other peripherals like the TS 2050 Modem became available later. Westridge Communications, the actual manufacturer of the modem, went ahead and sold the units that had been ordered by Timex, on their own along with

## InfoWorld

Report Card

### Timex 2068 Color Computer



	Poor	Fair	Good	Excellent
Setup	<input type="checkbox"/>	<input type="checkbox"/>	<input type="checkbox"/>	<input checked="" type="checkbox"/>
Ease of Use	<input type="checkbox"/>	<input type="checkbox"/>	<input type="checkbox"/>	<input checked="" type="checkbox"/>
Performance	<input type="checkbox"/>	<input type="checkbox"/>	<input type="checkbox"/>	<input checked="" type="checkbox"/>
Documentation	<input type="checkbox"/>	<input type="checkbox"/>	<input type="checkbox"/>	<input checked="" type="checkbox"/>
Serviceability	<input type="checkbox"/>	<input type="checkbox"/>	<input type="checkbox"/>	<input checked="" type="checkbox"/>

Above: Even "snobbish" magazines gave Timex's new computer a good report card. Below: The original ZX Spectrum has literally thousands of software titles available. It's only drawback...a poor keyboard.



- A-TS 2080 80 Column Printer
- B-TS 2065 Micro-Drive
- C-TS 2050 Telecommunications Modem
- D-TS 2060 System Expansions Unit
- E-TS 2020 Cassette Program Recorder
- F-TS 2068 Personal Color Computer

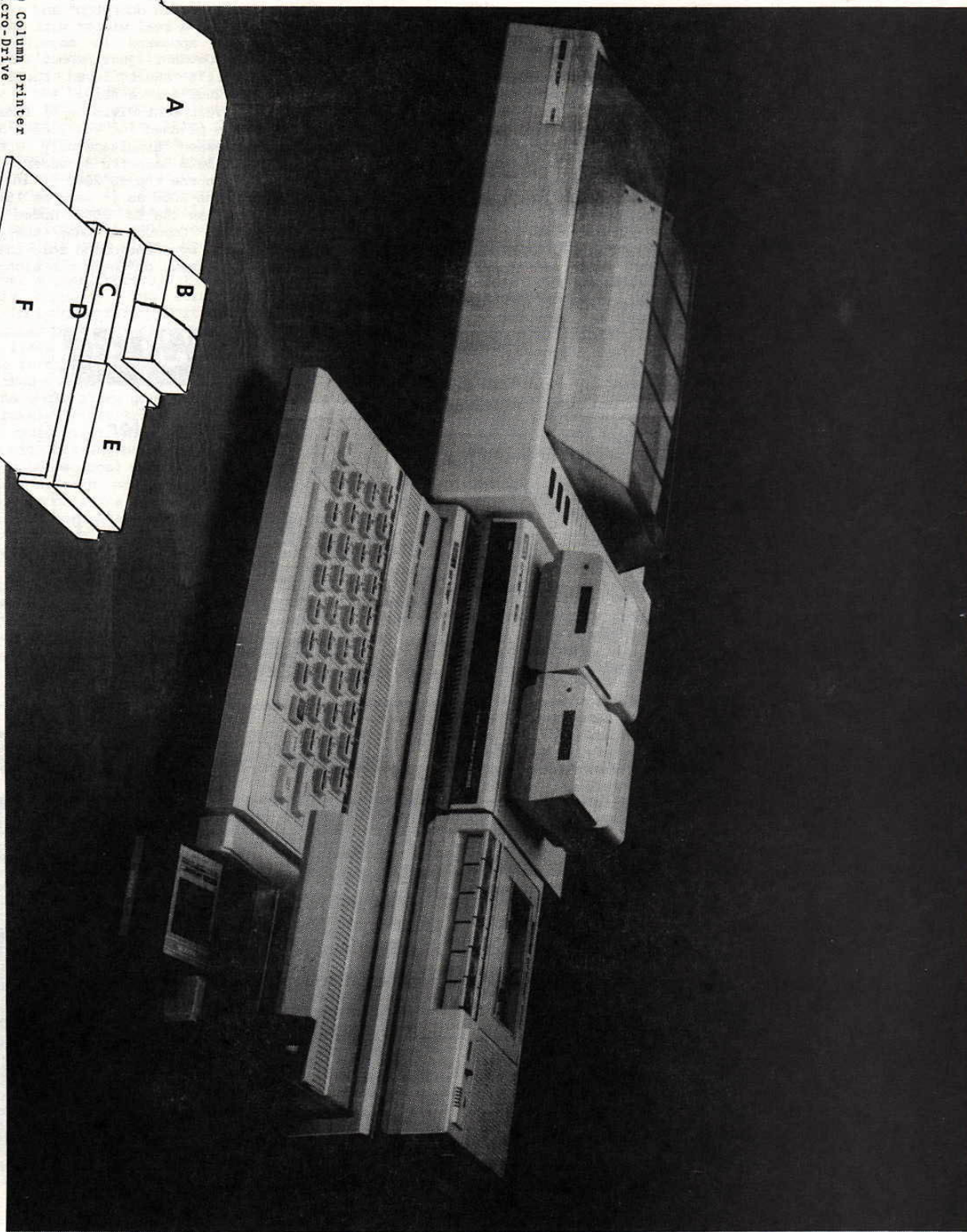
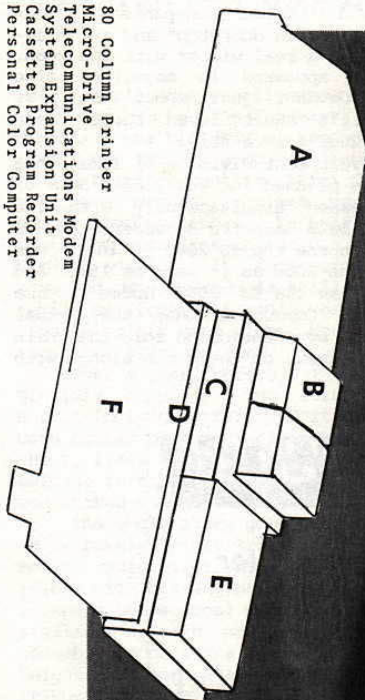

the terminal software that had been developed by Micro-Systems Inc. (a Florida-based software company).

One of the more anticipated add-ons by "cassette-weary" Timex users, were the Microdrives—a unique data storage medium. Sinclair Research again developed this technology, and had units available for the Spectrum. The Microdrives used small wafer cartridges containing an "endless" loop of magnetic tape. Preliminary specs called for 100k of data storage per wafer, with an average load time of four to ten seconds. The American version of the Sinclair Microdrives were to be called the TS 2065. While the 2065 wasn't ever released, the actual Sinclair drives are easily adapted to the TS 2068 with a suitable rear buss expansion card and a Spectrum Emulator.

At the Boston Computer Society's TS Celebration held in October of 1983, then Timex Computer Division Chief, Dan Ross, demonstrated a device which was referred to as the "Chameleon" or Spectrum Emulator. This device, when plugged into the 2068 cartridge port, transforms the 2068 into a ZX Spectrum allowing the user to run virtually any Spectrum software or attach Spectrum hardware devices. Although the 2068 is based on the Spectrum design, the two machines have different operating ROM's. The Emulator simulates the Spectrum ROM. Another method is to physically swap the computer's ROM's, or install a switch between them, with the Spectrum ROM mounted on a separate little circuit card. The Spectrum Emulator allows the 2068 user to access the almost 5,000 software titles available for the Spectrum. Thanks to some enterprising individuals, the Spectrum Emulator is available today from several dealers and in different configurations.

Another device, the 2060 Expansion Unit (or Bus Expansion Unit [BEU]) is shown in a Timex photo "piggy-backed" to the rear of the TS 2068, while other Timex peripherals are shown sitting atop the device. The 2060 remains a mystery in most TS circles today, and is shrouded in rumor and secrecy to some degree. It was never manufactured by Timex, and most likely will never become available. This low-profile box was to contain several components to greatly increase the power of the 2068. First of all, the 2060 contained the controller card for the Microdrives...essentially the circuitry found in Sinclair's Interface One. Some believe that it would also have contained an optional floppy disc controller card as well as a CP/M card. Secondly, it would have offered several interfaces not available on a stock 2068, such as an RGB monitor interface, a Serial port, and a Centronics-type printer interface. Finally, and most important (and most mysterious), the Timex 2060 contained the external banks of RAM and associated circuitry alluded to in the Timex literature. Once source quotes up to 256k of bank-switched RAM!

Four other items worthy of mention (two of which became available and two which didn't), are the original Timex 64 column Word Processor called MSCRIPT, and spoke of in the 2068 promotional literature, and the TS 2068 Technical Manual, both of which are currently available. A Timex-designed composite monitor which would have been manufactured by Samsung in Korea, and a full size 80 column NLQ printer was scheduled to be produced by the Japanese firm, Sekosha. Both of these items never rolled of the assembly line with a Timex decal. The printer, however, is offered by Radio Shack for their Tandy line of computers.

We do know today, that the research and engineering of the Timex Sinclair technology was moved from the Connecticut office after the shut-down of Timex's U.S. computer division, overseas to the Timex factory in Portugal. This factory was greatly involved in the manufacturer of a number of Timex computer items including the ZX81/TS 1000, the TS 1500, earlier versions of the Sinclair Spectrum, as well as 2068 "Command Cartridges" and many parts for the 2068. Timex of Portugal went on to further refine and develop 2068 technology for sale

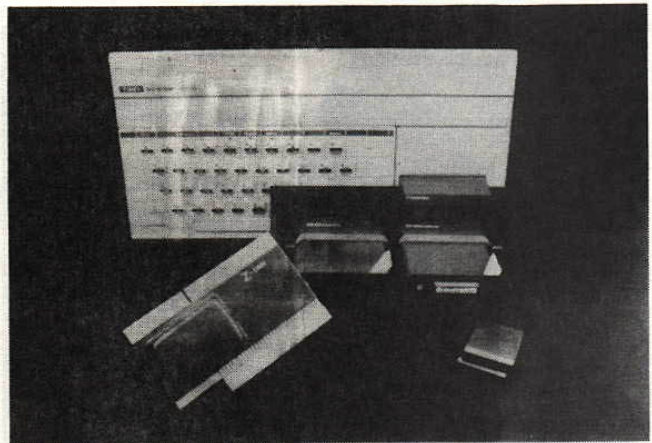

Above: TS 2068 shown with the Sinclair Microdrive System. The ZLINK adapter and Spectrum Emulator cartridge shown were designed and manufactured by Clifford & Associates.

in Europe and now some communist-block countries. For instance, they offer a 2068 that has the cartridge port section removed, and a "rock-steady" video display. In replace of fast load cartridges, they offer a superb floppy disk system incorporating 3 inch Hitachi-style drives.

In late 1984, I became involved in a project called TIME DESIGNS MAGAZINE, as editor and manager. This bi-monthly magazine had several goals at the time of conception: 1. To fill a void created by the departure of SYNC, TIMEX SINCLAIR USER, and SYNTAX from the TS publishing business. 2. To offer the very best magazine possible under the circumstances with the budget and resources available. 3. Customer satisfaction is number one considering how most of our customers have been "burned" in one way or other. Starting with just a \$20 investment, myself and a couple of other associates (including my wife), we made some flyers and bought some stamps. It seemed like forever, but after our first issue (a downright crude first effort) we gained 100 subscribers. Right then and there, it was decided that if we were going to spend the time, money and energy on the project, then "why don't we do it in a big way?" From there, we rented address lists, took out ads in other publications, and basically a lot of old fashioned hard work.

Today, after over two years in the business, we have started to figure out how things are done, and I feel that we have met those original goals. In late 1986 our mailing list included more than 3,000 Timex Sinclair readers.

Interest in "Uncle Clive's" machines has not waned. Many have referred to the following as "cult-like". ZX81 users are still improving on the old technology by stripping out the motherboard and re-casing the package complete with a real keyboard. Much experimentation with hardware and software applications continue. TS 2068 users also have endured, and overall I would say there is much more available for the 2068 now, then there ever was when Timex was still in the business. Many of the "promises" they made, have actually come true, thanks to a lot of dedicated enthusiasts. Other Sinclair computers have a following also including the new Quantum Leap and the time-less Spectrum.

The following collection of articles, programs and reviews of products are taken from the first six issues of TIME DESIGNS MAGAZINE (our first volume). I re-edited and "cut and pasted" a lot of it, as some of the earlier

Continued Next Page...

material had become outdated a bit. But I have tried to leave all of the current information in to the best of my knowledge. Information is grouped together for the particular Timex computer models, and not as they appeared in TDM. As an added bonus, in the back of this collection is a current listing of TS user groups and TS dealers and suppliers.

It is our hope here at TIME DESIGNS that you find VOLUME ONE to be useful and informative, and we wish you many happy hours of computing.

Tim Woods  
Editor

## micro muse

### FORE AND NEXT

by: P. Bingham

"Personal Computers?" It seemed far-fetched.  
We viewed in awe technology's stretch.  
ENTER THE DEALERS; (with mottos iced)  
"Computing Power...but at a price."

Our british uncle balked and said,  
"Z-X-eighty for you instead."  
Computers by mail? "They must be hexed!"  
Our Z-X-eighty-one was next.

Like hot cakes running low on syrup,  
Timex climbed up in the stirrups.  
"We'll sell two million, maybe more!"  
1000s sold in every store.

The market bucked, the market kicked.  
"After this licking will Timex tick?"  
And can the Spectrum reach the gate?  
Is it?...It is!...the Sixty-eight."

Sales were brisk, though still in hiding.  
(Timex continued right on sliding.)  
TI's door-slam made us swallow.  
"Where might we be left to wallow?"

Tomorrow brought unwelcome news:  
"You've just contracted the Timex Blues.  
Sync is sunk, the rumors riz,  
I wonder where the info is?"

Amid the flurry ensigns rise...  
"We're not alone, we've still some ties!"  
Unshelved 'sixty-eights were humming.  
Software titles were slowly coming.

Along came someone who made a "switch"  
and saved yet more from being ditched.  
Wizard disciples of uncle Clive's  
unveiled the latest: REAL-LIVE-DRIVES!

Indeed not dead, not even dying,  
our proud crowd keeps skyward flying.  
And shepherd Clive asks of his sheep,  
"Are you now ready for Quantum Leap?"

(Thanks to Paul Bingham of Pleasantrees  
Programming for sharing one of his many  
talents with us.)

## INTRODUCTION

OK all you T/S 2068 buffs,  
dust off that ZX81 or T/S 1000  
(excuse me for a moment ZX81 and  
T/S 1000 users) and let's do some  
serious things with your computer.  
No, I'm not talking about doing  
your income taxes, balancing your  
checkbook or writing your first  
novel. When I say serious, I mean  
controlling something with your  
computer. Although you can use your  
T/S 2068...your ZX81 or T/S 1000  
will do the job very nicely too.

Control what, with your com-  
puter? Control anything you think  
might be nice to control. Your  
lights, your garage door, your  
coffee pot or even your personal  
robot. PERSONAL ROBOT? Yes, your  
lowly T/S 1000 (excuse me again  
ZX81 and T/S 1000 users) is very  
capable of nearly anything you want  
to control with a computer. Remember  
those personal computer experts who  
brushed off the Sinclair and Timex  
computers as mere "toys" good only  
for learning about the basics of  
computing, but not for "serious"  
computing? Those "experts" now say  
you shouldn't tie up a personal com-  
puter with mundane home control task  
Well, the experts can be correct hal  
the time.

Even in the face of current 16  
bit and soon to come 32 bit home com-  
puters, don't let anyone sell the 8  
bit Z80 CPU computers short. The Z80  
based computers are an excellent  
choice for control applications. If  
you don't believe me, look to Japan  
where an assault on the small com-  
puter market has been launched with  
their MSX (MICROSOFT EXTENDED) com-  
puters. One of the prime reasons  
they selected the Z80A CPU was be-  
cause of it's potential for control  
applications.

In your ZX81 or T/S 1000 com-  
puters (include the T/S 1500, T/S  
2068 and SPECTRUM too) you have the

# TO COMPUTER CONTROL

by Bruce C. Taylor

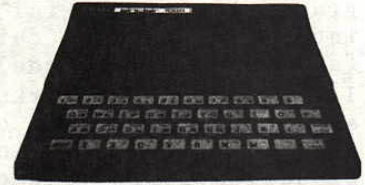
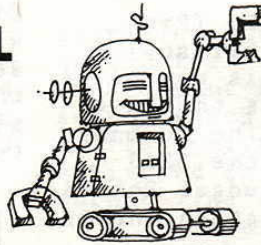

makings of a very capable computer control system. All you need to get started "interfacing with the world" is to add an input/output (I/O) board to your computer.

But wait a minute, before I launch into the details, you may have the following question. Why build a control project from scratch when I can buy a robot or home control/security system out of a box? First of all, it will probably be cheaper to build it yourself. Also, if you are inclined to tinker and build, you can continually expand and upgrade your system as you desire. This allows you to take advantage of new equipment/component advances, not to mention software upgrades.

For example, if you built a personal robot as I have done, you may have designed the controlling software to use the input avoidance technique of navigating around the house. With the addition of a range measuring device, like the Polaroid Ultrasonic Ranging Device, you can advance the navigation capabilities to a goal seeking ability. This can be done by modifying the software so that the robot seeks open areas to navigate through, much like you seek a doorway as opposed to avoiding walls in a room.

Back to the problem of building an I/O interface for your computer. Several options are available. One was described in a series of articles in RADIO-ELECTRONICS MAGAZINE last year. Another is an inexpensive I/O board offered by BUDGET ROBOTICS & COMPUTING of Tucson, Arizona. Both offer eight parallel lines of input and output, and use simple machine code subroutines to give a very fast I/O capability. How fast? The Budget Robotics board includes documentation for a simple optical encoder that can measure inputs up to several hundred pulses a second, and all for only a

few dollars. Is that fast enough and cheap enough to entice you to get on with this computer control area of interest?

Budget Robotics in fact offers an expanding line of peripherals including a buffered buss expansion board (currently for ZX81, T/S 1000 and T/S 1500) to allow you to add an almost limitless number of items in your computer control project. In fact, I have written a book describing these and other projects, to be published by early 1986 by TAB BOOKS. The centerpiece of the book is "H.E.N.R.Y." an internally computer controlled personal robot. He won a Golden Droid Award for Most Entertaining at the First International Personal Robot Congress & Exposition in Albuquerque, New Mexico last spring. What computer is inside H.E.N.R.Y.? You guessed it, a Sinclair ZX81. Hardware and software for all control projects is fully explained in the book. A home control interface is also described.

The expansion board used is the one originally built by COMPUTER CONTINUUM, but has been improved. This board can also be used to build a memory bank switching capability as described in Paul Hunter's series of articles in T-S HORIZONS Magazine. Using Paul's non-volatile memory board, control routines can be created and saved for instant loading into computer memory and easily changed as upgrades to your control project are needed. This method is cheaper and easier than burning Programmable Read Only Memory (PROM) chips, or trying to buy Electrically Erasable PROM (E2PROM) chips.

Other expansion boards and I/O circuits can be used which will also do a good job. John Oliger described an expansion board in a Winter 1982 SYNTAX QUARTERLY article. An I/O



circuit using the 8255 PPI (Programmable Peripheral Interface) integrated circuit chip is not as fast (no machine code) as the RX-81 I/O circuit, but works fine in many applications. Wiring of the 8255 circuit is included in Budget Robotics expansion board documentation and is described in my book.

To give you an idea of the range of control applications I am proposing, refer to Figure 1 as you read the rest of this article. Starting with the computer expansion port at the rear of your computer, you will want to add an expansion board if you expect to add more than two peripherals. Next you will need at least one input/output (I/O) board. The number and type of I/O boards will depend on what and how much you want to control. For example, you could easily add up to four RX-81 I/O boards and an 8255 PPI giving you up to either 56 input and 32 output lines or 32 input and 56 output lines. Each peripheral, as described in Figure 1, may require anywhere from one input line (optical encoder) to four input and seven output lines (realtime clock).

The following are examples using the RX-81 I/O board: A realtime clock/calendar using seven output plus four input lines to read the time. A mechanical switch can be read by connecting an input line to ground. A transistor to transistor logic (TTL) state of low can be read directly by an input line. A logic high state can be read if inverted first, using a 74LS04 IC chip. The Polaroid (TM) Ultrasonic Ranging Circuit requires one output line to initiate a pulse transmit and one input line to read the return pulse. One input line is all that is required to read the status of a phototransistor in the optical encoder.

The following are examples using the 8255 PPI circuit: Two output lines are used to control a stepper motor driver with one line designating the direction of the motor rotation, and the other producing the step pulse. Ten output lines are used to control the

Digitalker (TM) Digital Voice Circuit with two ROM (Read Only Memory) word sets with eight lines used to select the word; one to select the ROM word set and one to activate the processor to produce the word.

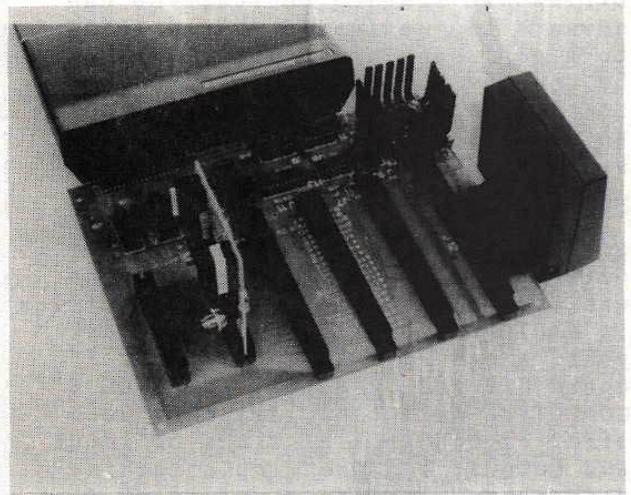
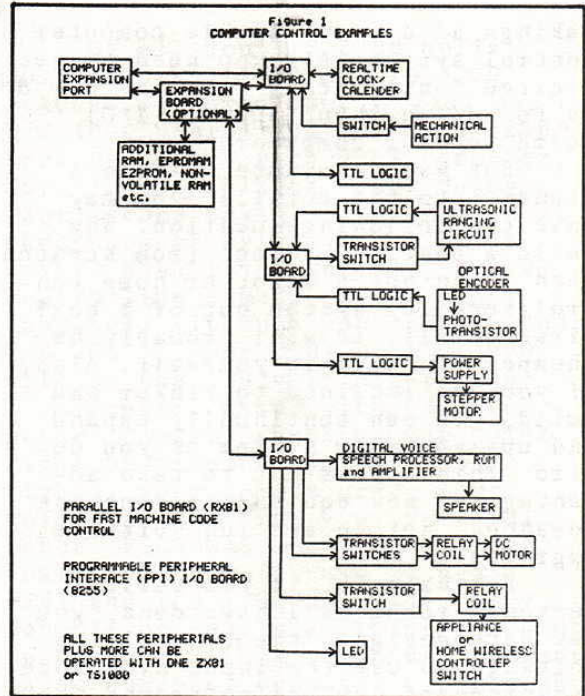

Above shows fully populated BUFFERED BUS EXPANSION BOARD and RX-81 PARALLEL I/O BOARD plugged into TS1000 with 16K RAM, 5 volt 3 amp regulator (top right), buffer/decoder ICs (across top), six expansion connector points (across bottom) with RX-81 I/O board plugged into expansion point second from left.

The following are examples of control easily accomplished using either of the I/O circuits mentioned: Two output lines are required to control a direct current (DC) motor and select either direction where one output line is used for forward and one reverse. Each drives its own transistor switch which in turn activates a double pole, double throw (DPDT) relay coil. The coils are cross wired to the normally closed terminal of the opposite relay so that power to the motor cannot accidentally be applied in both polarities at the same time, causing a direct short circuit. For appliance or home wireless control

switching, one output line is required for each on/off switch. Here each output line controls a transistor switch which in turn controls a relay. A light emitting diode (LED) can be activated in conjunction with any output line activity.

These examples are provided as food for thought. You can control virtually anything with your computer. Just use discretion. I would not recommend trying to control Aunt Mary's respirator. One last point, all the examples in Figure 1, plus more, can be controlled together by a single computer (ZX81, T/S 1000, ect.). Happy controlling.

T/S 1000/1500



## AUTOMATICALLY SET RAMTOP WITHOUT DESTROYING THE PROGRAM

by Earl Dunnington

How would you like to be able to set RAMTOP within your program? I was using a program "HEXEDIT" published by a former popular T/S magazine, when the program and the computer locked up. The author erroneously thought that merely poking the system variable "RAMTOP", in his program, would reset RAMTOP to a new location. This led to my research to find a method for setting RAMTOP within a T/S 1000 or 1500 program. The results of my research are presented in this article.

To see what happened with Doctor Hexedit's program, type the listing of figure No. 1 into your computer. Run the program. Wait about 30 seconds and watch the "inverse ? monster" eat up the program. You will have to pull the plug to unlock the computer. A modification of lines 50 to 80 are used in figure No. 3 as a test to see that RAMTOP has actually been moved. In order to understand why the program was destroyed, you must know the structure of the memory map of the RAM in more detail than the diagram in your users manual. The T/S 1500 manual diagram shows USR routine

space above RAMTOP. This is not the case unless the additional 16k Timex Rampack is attached or you have lowered RAMTOP.

Turn on your computer. Using immediate commands only PEEK into the system variable RAMTOP to determine its address. Then PEEK into each of the four Bytes under RAMTOP. Reading from the highest address down, you should find the decimal values: 62, 0, 6, and 118. The 62 is a flag to tell the computer "This Is The Top Of The GOSUB Stack". The zero and the six are flags to tell the computer to generate a code seven error. The 118 is the code for ENTER (N/L). When we poked 24 into each of these four bytes with the crash demonstration program, the computer went crazy trying to figure out what to do. Since RAMTOP had not really been lowered, when a large amount of data was entered, the HEXEDIT program over-ran the four bytes instead of giving an out of memory code 4 error report.

Peek into the system variable "ERR--SP". You will find the address of the fourth byte below RAMTOP. The machine

Stack Pointer, also known as SP, is a two byte internal set of registers that cannot be peeked into from BASIC. If we could then you would also find stored there the address of fourth byte below RAMTOP.

```

1 REM 12345678901234567890123
456789
2 REM CHANGE RAMTOP PROGRAM,
PART 1 BY EARL DUNNINGTON
3 REM FOR 16K RAM CHANGE LINE
20. THE 8TH VALUE TO 186 AND
9TH VALUE TO 119
4 REM FOR 2K RAM CHANGE LINE
20. THE 9TH VALUE TO 071
10 FAST
20 LET A$="205,035,015,205,042
,010,033,000,192,034,004,064,043
,054,052,043,054,000,043,054,006
,043,054,118,034,002,064,249,201
30 LET A=1
40 FOR N=16514 TO 16542
50 LET B=A+2
60 POKE N,VAL A$(A TO B)
70 LET A=A+4
80 NEXT N
90 REM TO CHANGE TO A VALUE OF
RAMTOP OTHER THAN 49152, REPLACE
THE EIGHTH VALUE IN LINE NO. 20
WITH THE LOW BYTE AND THE NINTH
VALUE WITH THE HIGH BYTE

```

FIGURE NO. 2

```

-----
COMPUTER CRASH DEMONSTRATION
-----
      8K ROM, ANY RAM
-----
10 REM COMPUTER "CRASH" DEMO
BY DUNNINGTON
20 SLOW
25 REM FIND PRESENT VALUE OF
RAMTOP
30 LET RAMTOP=PEEK 16388+256*P
EEK 16389
35 REM DR. "HEXEDIT" THINKS HE
SET RAMTOP AUTOMATICALLY TO
18176 IN HIS LINE 9710 BY THE
FOLLOWING POKE:
40 POKE 16389,71
45 REM TEST TO SEE IF RAMTOP
IS STILL AT THE ORIGINAL VALUE
BY POKING 24 INTO EACH OF THE 4
BYTES BELOW ITS ORIGINAL VALUE
50 FOR N=RAMTOP-4 TO RAMTOP-1
60 POKE N,24
65 REM PRINT ALLOWS YOU TO SEE
WHAT IS HAPPENING
70 PRINT
80 NEXT N

```

FIGURE NO. 1



The OP codes of the USR subroutine that is poked into the line 1 REM statement by the listing in Figure No. 2 are as follows:

16514	CD230F	CALL 3875	:SET FAST MODE
16517	CD9A14	CALL 2602	:CLEAR SCREEN
16520	21BA77	LD HL, 49152	:LET HL=DESIRED RAMTOP
16523	220440	LD (16388),HL	:SET SYSTEM VARIABLE RAMTOP TO 49152
16526	2B	DEC HL	:LET HL=HL-1 OR 49151
16527	36E3	LD (HL), 62	:POKE THE ADDRESS IN HL WITH 62
16529	2B	DEC HL	:LET HL=HL-1 OR 49150
16530	3600	LD (HL), 00	:POKE THE ADDRESS IN HL WITH 0
16532	2B	DEC HL	:LET HL=HL-1 OR 49149
16533	3606	LD (HL), 06	:POKE THE ADDRESS IN HL WITH 6
16535	2B	DEC HL	:LET HL=HL-1 OR 49148
16536	3676	LD (HL), 118	:POKE THE ADDRESS IN HL WITH 118
16538	220240	LD (16386),HL	:SET ERR--SP TO 49148
16541	F9	LD SP,HL	:SET STACK POINTER TO 49148
16542	C9	RET	:RETURN TO BASIC PROGRAM

```

1 REM LN 7?LN E**5 ""6,RNDFQYF
0 FQ,FQ
8706 TAN
2 REM CHANGE RAMTOP PROGRAM
PART 2 BY EARL DUNNINGTON
3 REM FOR 2K RAM DO NOT TYPE
IN LINES 2,3,4,50,70,AND 100 TO
150.
TO CHANGE TO A VALUE OF RAMTOP
OTHER THAN 49152, IF NOT ALREADY
DONE IN PART 1, POKE 16521 WITH
THE LOW BYTE AND POKE 16522 WITH
THE HIGH BYTE, BEFORE SAVING THE
PROGRAM.
4 REM SAVE THE PROGRAM ON
TAPE USING THE COMMAND GOTO 9910
RELOAD THE PROGRAM FROM TAPE
USING THE COMMAND LOAD "RAMTOP"
5 RETURN
10 SLOW
20 FOR N=1 TO 10
30 PRINT AT 17,7;"STOP THE TAP
E"
40 PRINT AT 17,7;"STOP THE TAP
E"
50 NEXT N
60 LET A=24
70 LET A$="RAMTOP IS NOW SET F
OR"
80 RAND USR 16514
90 GOSUB 5
100 PRINT A$;" ";PEEK 16388+256
*PEEK 16389,"THE VARIABLE A AND
THE STRING A$WERE NOT DESTROYED
NEITHER WAS THE PROGRAM."
110 PRINT AT 7,0;"RAMTOP TEST",
'
120 FOR N=32764 TO 32767
130 POKE N,A
140 PRINT PEEK N;" ";
150 NEXT N
9900 STOP
9910 SAVE "RAMTOP"
9920 GOTO 10

```

FIGURE NO. 3

Referring to Figure No. 3:

Line 1 is the REM line of figure No. 2 after the OP codes have been poked into it.

Line 5 can be any RETURN in your program  
Lines 10 to 50 place the flashing STOP THE TAPE prompt on the screen.

Lines 60 and 70 store a variable and a string before the change in RAMTOP.

Line 80 calls the M/L subroutine to set up everything for the change in RAMTOP.

Line 90 in conjunction with line 5 activate the change of RAMTOP.

Line 100 prints the value of the new RAMTOP and the other remarks.

Lines 110 to 150 make the test to see that RAMTOP was moved.

Line 9900 keeps the program from going into an endless SAVE loop.

Line 9910 makes the program self running if the program is SAVED using GOTO 9910.

Line 9920 tells the computer where to start running the program.

The change in RAMTOP must not be activated in a subroutine or in a FOR/NEXT loop. You can only set RAMTOP as high as the first nonexistent byte above your particular RAM. You must change RAMTOP by a minimum of four bytes.

The formula for the high byte is:  
 $HB = \text{INT}(n/256)$

The formula for the low byte is:  
 $LB = n - 256 * HB$

For the TS 1000/ZX81

## BOXES

By Stephen Brothers

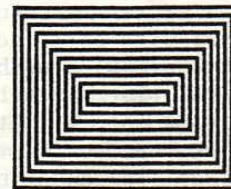

```

10 REM "BOXES"
20 REM
30 REM BY, STEPHEN BROTHERS
40 SLOW
50 LET G=0
60 LET J=43
70 LET H=63
80 FOR F=G TO H
90 PLOT F,J
100 PLOT F,G
110 NEXT F
120 FOR K=G TO J
130 PLOT H,K
140 PLOT G,K
150 NEXT K
160 LET J=J-2
170 IF J=21 THEN STOP
180 LET H=H-2
190 LET G=G+2
200 GOTO 80

```

# A MONITOR ADAPTER FOR THE T/S 1500

by Dick Wagner

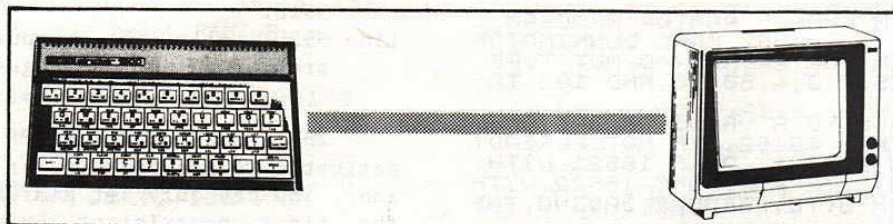

For several years, publications have carried articles on connecting T/S 1000 and ZX81 computers to monitors, to improve the quality of screen image that some TVs lack. There have been mainly 2 approaches, (1) install a complex converter to give a reverse screen image of white on black, (2) install a simple transistor adapter to match the computer output to the low impedance of the monitor. This gives a normal screen. Number 2 is the easiest and the method is described. On a T/S 1000, the procedure is to tap pin 16 on the Sinclair special IC.

The literature seems to have neglected the T/S 1500. Possibly because the RF modulator is special, or possibly because of the weak signal provided by the newer SCL IC. The writer has converted two T/S 1500 computers with satisfactory performance; one with a B&W Zenith monitor, and one with a NEC color monitor.

This article is not a detailed instruction of my method, so if the reader is not well versed in handling circuit boards and components, it is recommended that you get help from a member of your users group, an amateur radio operator, or someone in the radio and TV service business.

Only a few parts are required. The first step is to obtain the transistor, resistor, cable and phono plug or jack, and some wire. The transistor is type 2N2-222 which is Radio Shack number 276-2009. The resistor is a 1/4 watt 220 ohm size, but may be 270 to 330 ohms. The phono jack can be R-S type 274-337 if the T/S cable is to be used for monitor connection. A short shielded audio cable (6-8 inches) will provide the computer connection with the jack on the free end. If it is desired to install a single cable to the monitor, then use R-S 42-2370. This provides a matching plug to fit the monitor jack.

To assemble the adapter, fit the resistor to the flat of the the transistor, cutting one wire lead to solder to the emitter lead, close to the transistor's body. Trim close to the solder connection if the resistor lead protrudes. Do not cut the transistor lead at this time.

Strip the outer insulation from the audio cable, about 3/4 in., and twist the shield wire together. Strip 1/8 in. from the core insulation and solder the center wire to the emitter lead. This lead should be insulated and brought parallel with the resistor. Cut excess wire from this connection. The other end of the resistor should be soldered to the twisted shield of the audio cable. These connections will give an output from emitter and will also ground the resistor. The resistor connection should be close to the cable, to leave the twisted shield for another connection. Using two light-insulated wires (like 30 gauge wire wrap), make your connections to the transistor base and collector leads after they have been shortened. These two wires can be 2-3 inches long. Follow the lead positions as per R-S package.

The assembled module should be insulated so no bare wires are exposed. Wires within the module also should be insulated from each other. Heat shrink tubing or plastic tape can be used. The assembly should have two leads of light gauge wire coming out of one end. These should be marked some way...the transistor collector is +5 volts and the base lead. The other end has the signal out and the ground wire (shield). The shield can have a short but heavier wire (20-24 gauge) soldered to it at this time. This will be a ground wire and a strain relief.

Disassemble the 1500 case by removing five screws and carefully remove the two ribbon cables from their connector blocks.

Then remove one screw to release the circuit board from the base. With the component side up, determine the location of resistor R30. It is close to the inside corner of the modulator box. Connections will be made to each end of this resistor. The end closest to the modulator box will be connected to the base of the transistor and the other end is +5 volts. See the diagrams for location.

Now make the connections noted above. Be sure the leads are correct before soldering. Solder with light heat, so the circuit board connections will not be damaged as a result. Cut the ground wire short, so when soldered to the ground connection for the jack, it will bring the module close over the jack. The other wires must be slack. Now apply power to the board and connect to the monitor. The cursor will show on the screen if everything is OK.

Exit to the rear when the circuit board is installed in the bottom of the case. Decide how to make the exit thru the top rear. If the cable is small enough (1/8 in. dia.) then it can use the same notch for the modulator cable. Light filing may be required to get around the modulator box. If the cable is heavier, file a notch in the back between the jack and modulator box. Connect the keyboard cables using needle nose pliers. Be most careful not to bend the cables sharply. If a cable is damaged, noted by a crack in the trace, use a sharp knife to separate the insulator cover on the cable. About 3/16 in. will do, and trim with some sharp thin scissors. Cut the cable at the crack so there will be a new end.

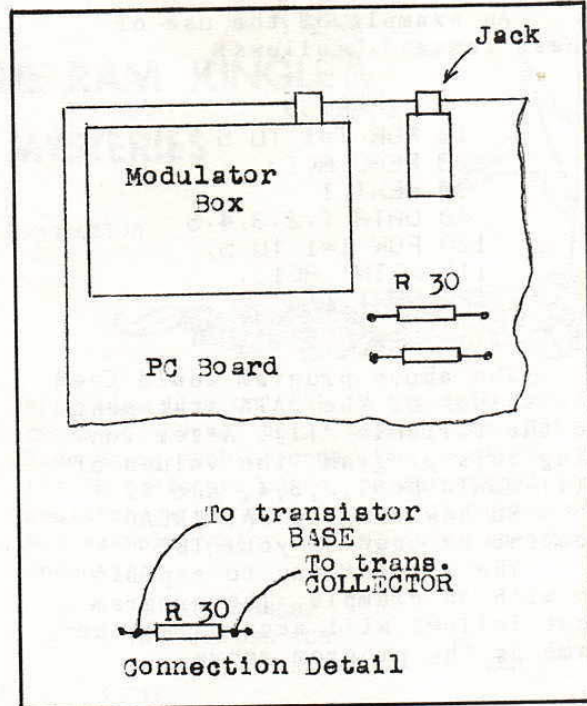

For further reference:

The Explorers Guide To The ZX81  
 The Best Of Sync  
 Sync Vol. 3 No. 4  
 SyncWare News Vol. 1

## DATA/READ on a TS 1000

by Bill Johnson

Many of you have discovered the ZX81 Computer does not have the DATA and READ commands in its vocabulary. These commands are the backbone of BASIC programming. You may have been unable to enter many programs written for other computers since you did not have the power of DATA and READ. The following only applies to the TS 1000, TS 1500 and Sinclair ZX81. The TS 2068 uses the DATA and READ commands.

First, let's define the commands:

DATA- The DATA statement is a place to store values. Each value is separated by a comma. The values entered into a DATA statement can be alphanumeric in nature.

READ- The READ statement inputs the values from the DATA statements, into variables defined in the program.

An example of the use of these commands follows:

```
5 DIM A(5)
10 FOR I=1 TO 5
20 READ A(I)
30 NEXT I
40 DATA 1,2,3,4,5
100 FOR I=1 TO 5
110 PRINT A(I)
120 NEXT I
```

The above program would feed the values of the DATA statements to the variable A(I). After running this program, the values of A(I) would be 1,2,3,4, and 5.

So how can the DATA/READ routine be used on your TS?

The easiest way to explain is with an example. The program that follows will accomplish the same as the program above.

```
10 LET A$="1,2,3,4,5,"
20 DIM A(5)
30 LET X=0
40 LET Y=1

50 FOR I=1 TO LEN A$
60 IF A$(I)="," THEN LET X=X+1
70 IF A$(I)="," THEN LET A(X)=
VAL A$(Y TO I-1)
80 IF A$(I)="," THEN LET Y=Y+1
90 NEXT I
100 FOR I=1 TO 5
110 PRINT A(I)
120 NEXT I
```

The lines 100 to 120 simply show you the results, they are not needed. We will now go line by line.

LINE 10: Acts like a DATA statement. You store your values here. It is important to end this statement with a "," or the last value will not be input.

LINE 20 to 40: These lines set various variables.

LINE 50: This line sets a loop the length of A\$. In this case the length is 10.

LINE 60:to 80: These lines all ask the question, "is the

next item in A\$ a ",". The comma is used to separate each value. If a comma is found, line 60 increments X by 1. X is used to set the value of A, the letter of the variable being read. LINE 70: Stores the value into the variable A. Line 80 increments Y, which is the starting place for the next value.

As you can see the above program accomplishes the same as the DATA/READ commands. The above routine can also be used to read in ALPHA values, as follows:

```
10 LET A$="H,B,C,D,E,"
20 DIM B$(5)
30 LET X=0
40 LET Y=1
50 FOR I=1 TO LEN A$
60 IF A$(I)="," THEN LET X=X+1
70 IF A$(I)="," THEN LET B$(X)
=A$(Y TO I-1)
80 IF A$(I)="," THEN LET Y=Y+1
90 NEXT I
100 FOR I=1 TO 5
110 PRINT B$(I)
120 NEXT I
```

This program works the same way as our previous program. One limitation is that you can not use the "," character in your values, or the program will consider this a stop point.

The above routines can be used to read values for various variables at the same time. For example, you may have a DATA statement: 1,A,2,B,3,C,4,D,5,E. You can read the values by combining the methods used above. I will leave this for you to do.



# ADVENTURES IN THE RAM JUNGLE AND OTHER MYSTERIES

by Earl V. Dunnington



In my article "Automatically Set RAMTOP Without Destroying The Program" published in the July-August issue, the GOSUB stack was very briefly discussed. This article will delve more deeply into this subject. I will also cover how to determine the extent of the "Safe Area" in the TS 1000 and 1500. The safe area determines the amount of bytes you can lower RAMTOP without interfering with the execution of the BASIC program. The safe area can be used for the temporary storage of data or machine code, without lowering RAMTOP. The safe area extends from the top of the Calculator stack to the bottom of the Machine stack.

There are three stacks in the upper RAM memory; the Calculator stack (C stack) the Machine stack (M stack), and the GOSUB stack (GS stack). All of these stacks are used by the routines in the ROM to store temporary data and variables. An item in the GS or M stacks consists of two bytes. The low byte is in the lower address and the high byte is in the next higher address. Items are added to the bottom of either the GS or M stacks. In the TS 1000 and 1500, the GS stack is located immediately below RAMTOP and above the M stack.

In the RAMTOP article we examined the four addresses below RAMTOP, using the PEEK command. A diagram of the values found in these four addresses is in Figure No. 1. In the same manner we examined the contents of the system variable ERR\_SP and found that it pointed to the address RAMTOP-4. The TS 1500 Users Manual defines the system variable ERR\_SP as the address of the first item on the M stack. The bottom of the GS stack is this address plus two (2). The Stack Pointer (SP) consists of two internal registers. The contents of the SP registers normally point to the address of the low byte of the last

effective item on the M stack. The SP registers cannot be addressed from BASIC. Even using machine code, the contents of the SP registers cannot be determined immediately after the computer is turned on. For example, enter the following into your computer:

```
1 REM 1234567
10 RAND USR 16516
20 PRINT PEEK 16514+256* PEEK
16515
```

then:

```
Z80 assembler
POKE 16516,237 ED      : prefix
POKE 16517,115 LD(NN),SP : Let 16514 and
POKE 16518,130 N       : 16515=con-
POKE 16519,64  N       : tents of SP
POKE 16520,201 RET     : Return to
                        : Basic
```

Now RUN the program. The result on the screen is the address at which the SP registers are pointing after calling the machine code USR function. You can see

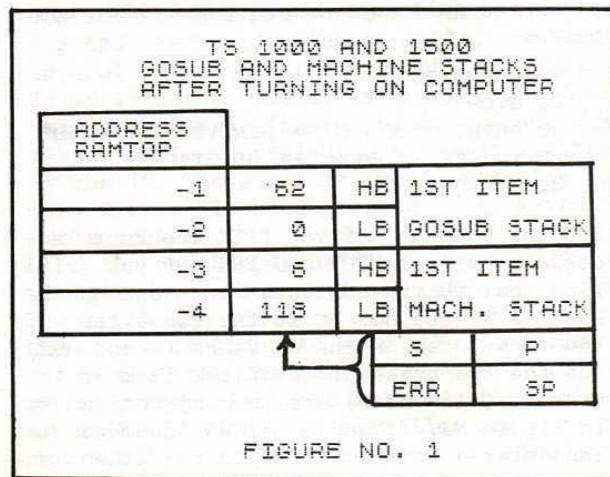



that the function itself uses the M stack. Then how do I know that immediately after turning on the computer, the contents of the SP registers is the address of RAMTOP-4? Only by deduction from the disassembly of the ROM, GOSUB and RETURN routines. They would not work unless the SP registers were pointing to RAMTOP-4. The address in the ROM of the GOSUB routine is 3765d and of the RETURN routine is 3800d.

Figure No. 1 shows the situation after the computer is initialized and after each BASIC line has been executed. The one exception that I know about is after one or more GOSUB commands and before any RETURN command. For an example of the exception, enter the following lines into the computer (after entering NEW):

```
10 GOSUB 20
20 STOP
```

RUN the program. Using immediate commands, PEEK into each of the addresses from RAMTOP-1 to RAMTOP-6. Also PEEK the two bytes of ERR SP, using the immediate command PRINT PEEK 16386+256\*PEEK 16387. Your results should agree with the values shown in Figure No. 2. We must assume that the SP registers are also pointing to RAMTOP-6 as the ROM RETURN command routine would not work if this were not true. Looking at Figure No. 2, you can see how the GOSUB command has slipped the GOSUB line number plus one onto the bottom of the GS stack, moving the first item of the M stack down two addresses. A GOSUB line number plus one, once used, is written over by moving the first item on the M stack up two addresses and changing the pointers SP and ERR SP. For example enter NEW and then enter the following lines into the computer:

```
10 GOSUB 30
20 STOP
30 PRINT "THE RETURN REMOVES THE GOSUB
LINE NUMBER +1 FROM THE GS STACK"
40 RETURN
```

RUN the program. If you PEEK the four addresses below RAMTOP and ERR SP you will find that their contents are again the same as Figure No. 1. If the two bytes of the first item on the GS stack (0 and 62) and the two bytes of the first item of the M stack (118 and 6) are in conjunction as in Figure No. 1, and a RETURN command is encountered in the BASIC program, then an error report 7 (RETURN without a corresponding GOSUB) is generated. The ROM rou-

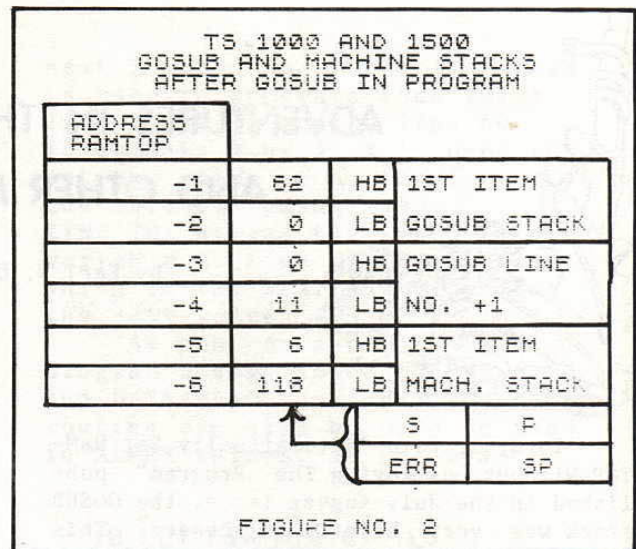

tine tests only for the high byte 62. As  $62*256=15872$ , this is beyond the normal maximum line number 9999. It is possible to use higher line numbers by working from the top of the program and POKEing 16509 with the high byte of the line number and POKEing 16510 with the low byte as each line is entered with a normal line number. In this case, line numbers with a high byte of 62 must not be used with a GOSUB command. If the two bytes of the first item on the GS stack and two bytes of the first item on the M stack are separated by the two bytes of a GOSUB line number+1, then the next line after the GOSUB line is executed when the RETURN command is encountered.

What is that 118 and 6? To find out, we know that an item on the M stack consists of two bytes, the low byte in the lower address and the high byte in the higher address. So  $118+256*6=1654$ . The addresses in the ROM run from 0 to 819d. Let us use the 1654 as an address in a machine code program and see what happens.

```
1 REM 123
10 RAND USR 16514
20 PRINT "THE ADDRESS 1654 STARTS THE
EXECUTION OF THE NEXT BASIC LINE OF THE
PROGRAM"
```

Now in the immediate mode, POKE the following into the REM line:

```
Z80 assembler
POKE 16514,195 JP NN : GOTO
POKE 16515,118 N : 118+
POKE 16516,6 N : 256*6=1654
```

RUN the program and you will see the answer on the screen. Note that using a 118 in the machine code messes up the display, but the program still runs.

Since the M stack expands downward in memory as items are added to it or to the GS stack and then, in effect, contracts as items on the stacks are no longer needed, but not withdrawn, a trail of garbage is left behind. This garbage is written over the next time the stack expands. Turn off your computer and then power up again. Using the immediate command, PEEK into the address that is the value of your RAMTOP minus 50. You should find 129. PEEKing below this address you will find only zeros. (Unless you PEEK all the way down to the top of the Calculator stack. This means that in the initialization ROM routine, the M stack was expanded down to this address. Now enter and run the following program, changing line 10 to the applicable values for your RAM memory:

```
10 FOR N=(your RAMTOP-50) TO (your RAM-  
TOP-5)  
20 POKE N,0  
30 PRINT PEEK N;" "  
40 NEXT N
```

What happens is that between the time 0 is poked into the M stack and the value at address N is peeked, the M stack is being used by the ROM routines which are much faster than BASIC. PEEK again, using the immediate command, into the address of your RAMTOP-50. Once again the value at that address is not 0 but 129. Peeking below that address there are only zeros. From this we can deduce that coming out of a BASIC program, the ROM routines use the M stack down to RAMTOP-50 and that the little program did not expand the M stack below this point. So the upper limit of the safe area for this program is: RAMTOP-51.

---

## NEW PRODUCTS FOR THE T/S1000

reviewed by Dick Wagner

### 8k ROM UPGRADE

A recently released ROM upgrade in the form of an EPROM and special adapter, provides needed improvements in manufacturers original equipment.

Major changes include: normal FAST mode, 6 character shape improvement, change British Pound symbol to apostrophy, LPRINT of decimal numbers with leading zeros, fast SCROLL, proper application of divide of numbers in repetitive math, proper CLS action, fixed display file, the ability to DIMension large single string arrays (with 64k), and the ability to invoke LPRINT commands by using RAND.

Directions for installation leave out several important warnings. The IC installation must be the same direction as the original. This is determined by a half-round notch on top of the IC. This is toward the back of the circuit board. Check your computer manual for proper location of the ROM IC. However, on my computer the

board is different and the ROM is to the right of the CPU. My ROM was marked MK368 09N. Instructions are given should the ROM be soldered in.

The new ROM has more pins, so it must contact all the pin sockets. When installing the keyboard ribbon cable, be very careful not to buckle or crack the ribbon. In my situation the IC is against the case when the board is in place. Also, the ribbon cable is deflected sideways slightly by the IC. These points need watching if your ROM is located behind the keyboard cable sockets.

The new ROM manual includes the MC of changes made, plus a description of what these changed routines do. Two short programs are included to show the improvement in some of the changes. One part of the major program includes filling the screen with "X" 10 times and scrolling and printing a column of "Y" each time. In SLOW mode

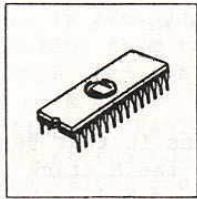

the original ROM processed this in 72 seconds on my 1000, while the new ROM required 45 seconds.

A peculiarity noted was that 7 seconds was required to display a 25 line program (in manual) following loading from tape, and ENTER. This seemed to be long by any standard. The program has a line to change from the now "standard" FAST, to SLOW. Deleting this line, saving and loading again, on ENTER the display was there in a flash. Further study has not been made on this.

Readers can order this improved ROM from Thomas J. Bent, 9016 Flicker Place, Columbia, MD 21045, or from Thomas B. Woods PO Box 64, Jefferson, NH 03583, and the price is \$20. Documentation is included.

## BANK SWITCHING AND OPERATING SYSTEM-BSOS

Paul Hunter has assembled many memory-use solutions in BSOS. Bank switching has been developed into a system much in the sense of DOS. So, what is Bank Switching? Reference to my computer encyclopedia indicates it is a method of extending RAM memory in computers. While each bank of memory responds to the same address, the system is arranged to have only one active bank at any instant. A bank is a block of memory, like 64k. I suspect Paul has coined BSOS.

Our ZX81s and T/S 1000s were not designed to handle over 16k of memory. Stretching to greater limits has required clever concepts by designers...and BSOS has incorporated additional RAM-like action, and the program to use the additional memory. As very long programs can strain 16k memories, likewise, large chunks of data can be a problem.

A program tape and sufficient documentation to get the user started, is available from Paul Hunter, 1630 Forest Hills Dr., Okemos, MI 48864. The taped program is to be used with a minimum of 64k of memory, and memory may be assembled from a series of 16k Timex modules, it may be purchased units such as Memotech 64, Byte-back 64, or it may be in the form of boards having both volatile and non-volatile memory. The T-S HORIZONS series includes the methods to assemble packs, make expansion boards and to combine various memory types to suit the users needs. Experiments in testing and programming are carried thru the series.

Some of the system concept available to the user (either entering a great deal of machine code or purchasing the tape) includes a real directory of up to 15 entries or instructions to SAVE, LOAD, PURGE, RECLAIM, PACK, BANK, ROOM and QUIT. Great flexibility is provided for almost any number of bank blocks. Use is made of the 8-10k block of RAM for operations.

Virtual memory is included in BSOS. This means that memory space (address) that the processor is using can be greater than actual memory. BSOS will give the user up to 80k bytes in length if there is a full complement of 4 banks. Even many of the concepts are useable with only 64k. It appears that considerable planning is necessary to properly segment programs and to use variables wisely. A point...while we normally can use 9999 line numbers, this program permits duplicate line numbers with proper segmenting. This is possible because program segments are moved into addressable space when required and then moved back when their need is ended. Data is also moved in this manner.

Users of large memory systems, not disk, ect., could well improve their operation with BSOS. Substantial speed improvement should be noted and a more professional system is provided the user.

While the purchase of the BSOS tape and document (\$10.00 ppd. from the address mentioned above) is a good buy, I suggest obtaining volumes 4,5,6,7,9,10,11 and 12 of T-S HORIZONS to have complete documentation and reference for BSOS.

After using "Firstloader" for quite some time, I felt that there was nothing that could be improved upon in programs that convert TS 1000 programs to the TS 2068. I was mistaken. In using "Firstloader", I found that my computer/recorder combination was one of those that required a load filter to work. With this "Basload" program I did not need a load filter.

The program consists of a BASIC portion, and of course, a Machine Code portion. The loading lines are more distinctive in the "Basload" program, and the acceptable volume settings are a little more broad. This program is supposed to also be able to convert variable data along with the BASIC program from the TS 1000 to the TS 2068. However, I had no program of that kind to test it on, so I can not verify this. One item bothered me somewhat about this program. The BASIC portion of the program is over-written when a program is converted. This makes it a little awkward to save the converted program (press NEW and start converting another program), but not impossible.

This is probably the best program on the market to convert your BASIC TS 1000 programs.

"Basload" sells for \$19.95, and is available directly from the author: Walter E. Styles, PO Box 325, Chester, VA, 23831, or also from Ramex International, Sharp's, and Curry Computer.

## BASLOAD

by Dennis Jurries



In the last issue, I took a look at JRC Software's "Great Game And Graphics Show" for the TS 2068, a collection of short programs exploring several aspects of that machine. In front of me now, is a similar program called the "Supertape" for the TS 1000/1500 or ZX81. The big difference here is that the "Supertape's" individual selections must be loaded in seperately, one at a time...sometimes a tedious task. I remember back to my BASIC computing course, when the instructor warned against putting too many programs on one tape, "because it is difficult to locate individual programs, and the possibility of losing data on tape due to accidental erasure". Oh well, with best intentions in mind, JRC put 45 short programs all on the "Supertape"(!)

There is so much here, that it would take a book to describe it all. In fact, JRC could take a hint by this, and offer the "Supertape" with some real documentation, instead of a long strip of 2040 printer paper. (How about a nice booklet.)

You get utilities like the assembler and text editors, mathematical programs like the plotters and statistics, games like Dodge and Dragon's Death, and lots of graphics routines, including "Oscilloscope". This was my ultimate favorite. In fact, I have never seen any animated graphics sequence on the TS 1000 quite like that one before.

A couple of suggestions. Read all of the REM statements in the program listings before you RUN the programs. They contain some helpful explanations. Also, almost every program can be sent to the printer, and individual screens can be copied... useful with the graphics programs.

In closing, I would recommend this program not only for the fine value (you really get your money's worth), but the author of "Supertape", John Coffey is a very good programmer, and I learned quite a bit of technique by taking the programs apart. Good humor abounds, and the variety is plentiful.

## SUPERTAPE

by Tom Judd



SOFTWARE

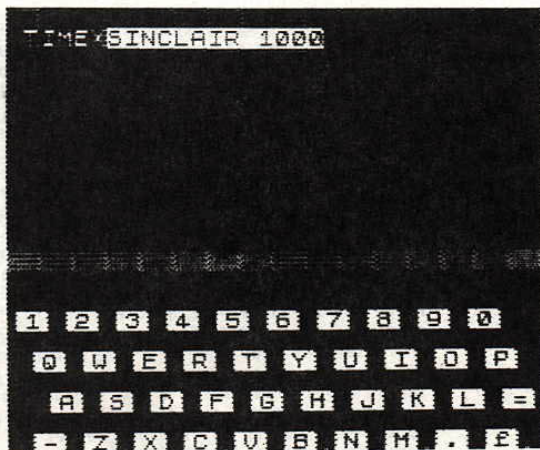

Here is a listing:

- |                          |                        |                                 |
|--------------------------|------------------------|---------------------------------|
| 1. Program Name Reader   | 16. Logo               | 31. Multiple Programs in Memory |
| 2. Loading Tip           | 17. Parm               | 32. Printer High Res            |
| 3. Flash                 | 18. 68 Lines           | 33. Magazine 1                  |
| 4. Bonus                 | 19. Flower             | 34. Magazine 2                  |
| 5. Wind                  | 20. Etchsketch         | 35. Cubic Maze                  |
| 6. 3D Plane              | 21. Speed Lander       | 36. Dragon's Death              |
| 7. Self List             | 22. Dodge              | 37. Oscilloscope                |
| 8. Character Set Bandana | 23. Keygame            | 38. 16K Tape Utility            |
| 9. 1K Text               | 24. Touch Type         | 39. 16K Assembler               |
| 10. Tape Unlocker        | 25. Statistics         | 40. Text 1                      |
| 11. Standard MC Loader   | 26. Slope              | 41. Text 2                      |
| 12. Beep and Phraser     | 27. FN Plot            | 42. Text 3                      |
| 13. Try This             | 28. Niche              | 43. Timex/Sinclair 1000         |
| 14. Just For Fun         | 29. Super FN Plot      | 44. JRC Poster                  |
| 15. Sines                | 30. Extension To Basic | 45. Printer Hi Res              |

A SUPERB HIGH-RESOLUTION GRAPHICS-DESIGN PROGRAM FOR THE ZX-81/TS 1000  
PLUS AN EXPANDED AND VERSATILE VERSION FOR THE T/S 2068...

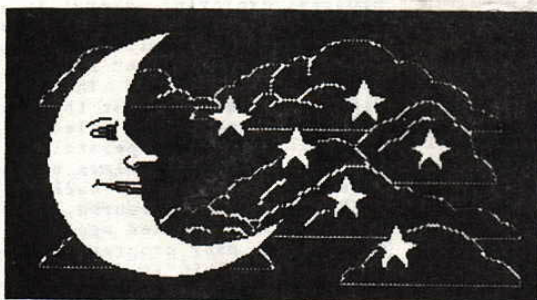

example 1

# PABLO PIXEL-O

by Michael E. Carver

I have thoroughly enjoyed my ZX-81 for years. I have added a full-size keyboard, 64k of memory and the Timex/Sinclair 2040 Printer. I've always lamented the lack of high-resolution graphics, but have never felt compelled to invest the extra money for the needed hardware or s/w. The following program will allow you to use your ZX-81/TS 1000/1500 and either the Sinclair or Timex Printer to create high-resolution graphics (see examples 1-4). Good-bye "blocky" pictures!

The characters of the ZX-81 are generated using an eight by eight grid. Each line of this grid is stored as a binary number in the ROM (addresses 1E00h to 1EE7h). If you were to PEEK the eight addresses for the letter "0" in the ROM, you would find the decimal/binary code in Fig. 1. For each "1" in the binary code, a pixel is set on the screen, producing the pattern "0".

Due to the design of the ZX-81, only codes stored in the actual ROM can be generated onto the screen without the use of extensive machine code programming. By using the routines contained in lines 500-570 and 1000-1090 of listing 1, and a lifted version of the LLIST subroutine from the ROM, any eight by eight character can be generated via your printer.

## USING PABLO PIXEL-O

The program is designed for you to draw a picture and create individual characters to produce a high-res copy of it. Graph paper which is ruled in eight by eight grids will help you map out your characters. Draw or trace your picture onto the graph paper. Next, darken each square (pixel) which is a line or solid/shaded element of your picture. (NOTE: if your picture does not contain an empty 8x8 grid, you may wish to define an

extra "space" character to help you in formatting later on.) Total up the number of different characters (8x8 pixel grid) you will need to compose your picture. Now count up the number of characters in each line (a max. of 32) and the number of character lines in your picture. You may wish to design your picture sideways and create a long panorama, but it can only be 32 characters high.

You are now ready to LOAD the program and begin creating your own characters. Before LOADING, you will need to lower RAMTOP by entering "POKE 16389,124", then followed by "NEW".

## DEFINING CHARACTERS

When the menu appears, choose option 1-- "Define Characters" (see fig. 2). This will set up a blank array in which to store your data. Answer the prompt with the total you calculated earlier. You may wish to enter a total slightly higher than the amount of characters you wish to define, allowing for any errors or additions. When prompted, enter each line of the 8x8 grid as a space or an inverted space (GRAPHICS/SPACE...see fig. 3). When this character is produced by the printer, a pixel will be set (black) for each inverted space and unset (blank) for each space. If, after entering all eight lines, you are not satisfied, answer "NO" to the prompt and you will have the option of starting over for that character or changing individual lines. (Keep track of the order in which you define your characters as they are coded and stored in this order. Character code "1" is for the first character defined, code "2" the second defined, ect.) After you have completed your character definition, the screen will go blank for a few seconds while the computer analyzes and stores the data. If you would like to return to the menu during definitions, enter "M" as the first space in any line. This will allow you to check your progress or save your data. NOTE: To continue definitions, choose option 2 "Continue Definitions", as option 1 will clear all data from memory!

## SEEING IS BELIEVING

You can review a portion of your work with "Big-Bits"--option 8. This option will display up to eight enlarged characters across and six down, using the standard Sinclair graphics. (See example 5) When prompted to enter

fig. 1

dec	binary
00	/ 00000000
01	/ 00111100
02	/ 01000010
03	/ 01000010
04	/ 01000010
05	/ 01000010
06	/ 01000010
07	/ 00111100
08	/ 00000000

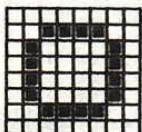



## BY THE NUMBERS

Line 1: Machine code for option 7 "Big-Bits"

Lines 2-3: Initializes flags

Lines 5-60: "Lifts" the LLIST routine from ROM and places it above RAMTOP with modifications.

Lines 100-130: Initializes array to store new character coding.

Lines 180-345: Accepts data for defined characters as a graphic binary code and changes the binary into decimal for storage.

Lines 350-390: Allows for corrections before storage of data is made.

Lines 400-495: Sets up picture array and accepts code numbers in the order you wish them printed.

Lines 500-565: Converts and stores character codes for printing of picture.

Lines 600-670: Contains the menu.

Lines 700-740: Sets up editing of already defined characters.

Lines 800-990: Subroutine which sets up data for the machine code for Big-Bits.

Lines 1000-1090: Stores the 8 lines of code for each character to be printed for each line of your picture and calls the LLIST routine store above RAMTOP.

Lines 2000-2040: Saves the program with any data entered.

Lines 9010-9170: Machine code loader.

Some of the Variables:

D(B): Holds decimal code for individual lines of character being defined.

D\$: Blank line to mask or clear prompts printed to the screen.

I\$(B,B): Accepts "plotted" version of character.

C: Total amount of characters to be defined.

C\$(C,B): Stores CHR\$ for the CODE of each line of defined characters. (By storing these codes in a String array we conserve memory. To store 100 characters using a numerical array would require 4K, opposed to 800 bytes using characters -- i.e. the number 53 is stored as "P".)

W & L: Width and Length, in characters, of you planned picture.

P(L,W): Contains character code numbers in the order to be printed.

L(32,8): Stores the eight lines of each character for printing of one line of the picture.

B(6,8): Stores the character codes in the order to be displayed during Big-Bits option.

example 2



example 3



example 4

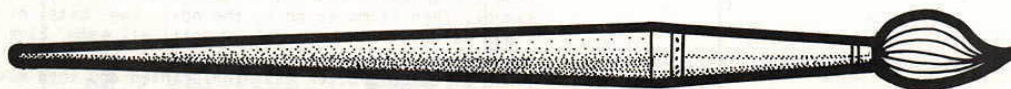

Listing 1



```

1 REM AAAAAAAAAAAAAAAAAAAAAA
AAAAAAAAAABBBBBBBBBBBBBBBBBB
BBBBBBBBBCCCCCCCCCCCCCCCCC
CCCCCCCCCDDDDDDDDDDDDDDDD
2 LET L=0
3 LET H=0
5 FAST
10 FOR I=0 TO 112
20 POKE 31744+I,PEEK (2161+I)
30 NEXT I
40 POKE 31800,63
50 POKE 31857,201
70 GO TO 600
100 CLS
105 DIM D(8)
110 DIM D$(32)
115 DIM I$(8,8)
120 PRINT AT 2,0;"HOW MANY CHAR
ACTERS DO YOU WISH TO DEFINE?"
125 INPUT C
130 DIM C$(C,8)
180 FOR F=1 TO C
200 PRINT AT 20,0;D$;D$;AT 5,6;
"1";AT 21,1;"12345678";AT 4,7;"
12345678"
205 CLS
210 PRINT AT 0,0;"PLOT OUT CHAR
ACTER ";(F AND NOT EDIT)+(H AND
EDIT)
215 PRINT AT 20,0;D$;D$;AT 5,6;
"1";AT 21,1;"12345678";AT 4,7;"
12345678"
220 FOR A=1 TO 8
225 INPUT I$(A,1 TO 8)
230 FOR E=1 TO 8
235 PRINT AT 20,0;D$;" 12345678
"
240 IF I$(A,1)="M" THEN GO TO
600
245 IF I$(A,E)=" " OR I$(A,B)="
" THEN GO TO 260
250 PRINT AT A+4,7;"RE-ENTER"
255 GO TO 225
260 NEXT B
265 PRINT AT A+4,7;I$(A,1 TO 8)
;TAB 6;CHR$(A+29 AND A<8)
270 NEXT A
275 PRINT AT 20,0;D$;D$;AT 20,0
;"ARE YOU SATISFIED?"
280 INPUT A$
285 IF CODE A$=51 THEN GO TO 3
50
290 FOR A=1 TO 8
295 LET D(A)=0
300 FOR B=1 TO 8
305 LET D(A)=D(A)*2+CODE STR$(
CODE I$(A,B)/128)-28
310 NEXT B
315 NEXT A
320 FOR P=1 TO 8
325 LET C$((F AND NOT EDIT)+(H
AND EDIT),P)=CHR$(D(P))
330 NEXT P
335 IF EDIT THEN GO TO 600
340 NEXT F
345 GO TO 600
350 PRINT AT 20,0;D$;D$;AT 20,0
;"DO YOU WANT TO CHANGE INDIVID
UALLINES?"

```

```

355 INPUT A$
360 IF CODE A$=51 THEN GO TO 2
05
365 PRINT AT 20,0;D$;D$;AT 20,0
;"WHAT LINE DO YOU WISH TO CHAN
GE?"
370 INPUT A
375 PRINT AT 20,0;D$;AT 20,0;"W
ORKING ON LINE ";A;AT 21,0;" 12
345678"
380 INPUT I$(A,1 TO 8)
385 PRINT AT A+4,7;I$(A,1 TO 8)

390 GO TO 275
400 CLS
401 PRINT AT 5,0;"HOW MANY SPAC
ES ACROSS WILL YOUR PICTURE BE?
(32 MAX.)"
403 LET RE=0
405 INPUT W
410 IF W>32 THEN GO TO 400
415 PRINT AT 8,0;"HOW MANY LINE
S WILL BE IN YOUR PICTURE?"
420 INPUT L
422 LET RE=1
425 DIM P(L,W)
430 CLS
431 PRINT AT 2,0;"ENTER CODE NU
MBERS FOR NEW,"CHARACTER SET I
N THE ORDER YOU WISH THEM TO B
E PRINTED."
432 IF A$="7" AND RE=1 THEN GO
TO 445
435 FOR Q=1 TO L
440 FOR R=1 TO W
445 IF Q>L AND R>W THEN GO TO
600
447 PRINT AT 19,0;D$;D$;AT 20,0
;"LINE ";Q;" / SPACE ";R
450 INPUT P(Q,R)
455 IF P(Q,R)=0 AND P(Q,R)<=C
THEN GO TO 470
460 PRINT AT 19,0;"INVALID INFU
T. RE-ENTER::"
465 GO TO 450
470 IF P(Q,R)=0 THEN GO TO 600

485 NEXT R
490 NEXT Q
495 GO TO 600
500 CLS
505 PRINT AT 2,0;"TURN PRINTER
ON AND PRESS ENTER WHEN READY T
O PRINT OUT YOUR PICTURE."
510 INPUT A$
515 FOR A=1 TO L
520 DIM L(32,B)
525 LET M=0
530 FOR B=1 TO W
535 LET M=M+1
540 FOR N=1 TO 8
545 LET L(B,N)=CODE (C$(P(A,M),
N))
550 NEXT N
555 NEXT B
560 GO SUB 1000
565 NEXT A
600 CLS
605 LET EDIT=0
610 PRINT AT 2,0;"**** PABL
O PIXEL-O ****"
620 PRINT AT 4,3;"DEFINE CHARAC
TERS.....1";AT 6,3;"CONTINUE
DEFINITIONS.....2";AT 8,3;"PIC
TURE CODING.....3";AT 10,
3;"PRINT OUT PICTURE.....4";
AT 12,3;"SAVE....."

```

```

...5";AT 14,3;"RE-DEFINE CHARAC
TER.....6";AT 16,3;"CONTINUE F
ICTURE CODING..7";AT 18,3;"BIG-
BITS.....8"
630 PRINT AT 20,4;"ENTER ONE OF
THE ABOVE"
640 PAUSE 4E4
650 LET A$=INKEY$
660 IF CODE A$<29 OR CODE A$>36
THEN GO TO 640
670 GO TO 100+(105 AND A$="2")+
(300 AND A$="3")+(400 AND A$="4
")+ (1900 AND A$="5")+(600 AND A
$="6")+(330 AND A$="7")-(30 AND
(A$="7" AND L=0))+(700 AND A$=
"8")
700 LET EDIT=1
710 CLS
720 PRINT AT 2,0;"WHICH CHARACT
ER DO YOU WISH TO RE-DEFINE? (
ENTER NUMBER)"
730 INPUT H
740 GO TO 205
800 CLS
805 DIM B(6,8)
810 PRINT AT 21,0;"HOW MANY LIN
ES? (6 MAX.)"
815 INPUT J
820 IF J>6 OR J<=0 THEN GO TO
810
825 PRINT AT 21,0;"HOW MANY ACR
OSS? (8 MAX.)"
830 INPUT K
835 IF K>8 OF K<=0 THEN GO TO
825
840 CLS
845 PRINT AT 2,0;"ENTER CODE NU
MBERS IN THE ORDER YOU WISH THE
M DISPLAYED."
850 FOR A=1 TO J
855 FOR B=1 TO K
860 PRINT AT 19,0;D$;D$;AT 20,0
;"LINE ";A;" / SPACE ";B
865 INPUT B(A,B)
870 IF B(A,B)=1 AND B(A,B)<=C
THEN GO TO 885
875 PRINT AT 19,0;"INVALID INFU
T. RE-ENTER::"
880 GO TO 860
885 NEXT B
890 NEXT A
895 LET NOTE=32000
900 FOR A=1 TO 6
905 LET M=0
910 FOR B=1 TO 8
915 LET M=M+1
920 FOR N=1 TO 8
925 IF B(A,M) THEN POKE NOTE,C
ODE (C$(B(A,M),N))
930 IF NOT B(A,M) THEN POKE NO
TE,0
935 LET NOTE=NOTE+1
940 NEXT N
945 NEXT B
950 NEXT A
955 SLOW
960 CLS
963 POKE 16622,J*4
965 RAND USR 16530
970 IF INKEY$<>" " THEN GO TO 9
70
975 IF INKEY$="Z" THEN RAND USR
16621
980 IF INKEY$<>"M" THEN GO TO
975
985
990 GO TO 600

```



```

1000 FOR J=1 TO 32
1010 FOR K=1 TO 8
1020 POKE 32255+K*8*(J-1),L(J,K)

1030 NEXT K
1040 NEXT J
1050 FOR H=1 TO 31
1060 POKE 16444+H,H
1070 NEXT H
1080 LET HCOPIY=USR 31744
1090 RETURN
2000 CLS
2010 PRINT AT 10,0;"ENTER NAME O
F PICTURE:::"
2015 INPUT A$
2020 IF A$="" THEN GO TO 2000
2025 PRINT AT 10,0;"READY TO SAV
E PICTURE: ";AT 12,0;A$;AT 14
,0;"TURN ON TAPE RECORDER","AND
PRESS ENTER"
2030 INPUT X$
2035 SAVE A$
2040 GO TO 5
3000 SAVE "PABLO"
3010 GO TO 1
9010 LET ADDRESS=16514

9020 LET A$="0087048302850681018
605820384078021007DE5E10E040604
56235E23E5AFCB1217CB1217CB1317C
B1317218240856F7E2A0E407723220E
4010E3D5111D0019220E40D1E10D20C
FE51180FF2A0E4019220E407EFE7620
BC11640019220E4023ED5B1040ED521
938ABE1C91618CD6B08C9"
9030 IF LEN A$<>226 THEN PRINT
"ERROR IN A$ PLEASE CORRECT."
9040 IF LEN A$<>226 THEN STOP
9050 FOR X=1 TO LEN A$-1 STEP 2
9060 POKE ADDRESS+INT ((X-1)/2),
(CODE A$(X)-28)*16+CODE A$(X+1)
-28
9070 NEXT X
9100 LET CHECK=0
9110 LET ADDRESS=16514
9120 FOR X=0 TO 112
9130 LET CHECK=CHECK+PEEK (ADDRE
SS+X)
9140 NEXT X
9150 PRINT "YOUR CHECK IS ";CHEC
K
9160 PRINT
9170 PRINT "IF CHECK IS NOT EQUA
L TO 9525 LOOK FOR ERRORS IN
A$"

```

### Listing 2

Address	Op Code (hex)	Mnemonic
16530	21007D	LD HL,32000
16533	E5	PUSH HL
16534	E1	POP HL
16535	0E04	LD C,4
16537	0604	LD B,4
16539	56	LD D,(HL)
16540	23	INC HL
16541	5E	LD E,(HL)
16542	23	INC HL
16543	E5	PUSH HL
16544	AF	XOR A
16545	CB12	RL D
16547	17	RLA
16548	CB12	RL D
16549	17	RLA
16551	CB13	RL E
16553	17	RLA

16554	CB13	RL E
16556	17	RLA
218240	LD HL,16514	
85	ADD A,L	
6F	LD L,A	
7E	LD A,(HL)	
2A0E40	LD HL,(16398)	
77	LD (HL),A	
23	INC HL	
220E40	LD (16398),HL	
10E3	DJNZ,16544	
D5	PUSH DE	
111D00	LD DE,29	
19	ADD HL,DE	
220E40	LD (16398),HL	
D1	POP DE	
E1	POP HL	
0D	DEC C	
20CF	JR NZ,16537	
E5	PUSH HL	
1180FF	LD DE,65408	
2A0E40	LD HL,(16398)	
19	ADD HL,DE	
220E40	LD (16398),HL	
7E	LD A,(HL)	
FE76	CP 118	
20BC	JR NZ,16534	
116400	LD DE,100	
19	ADD HL,DE	
220E40	LD (16389),HL	
23	INC HL	
ED5B1040	LD DE,(16400)	
ED52	SBC HL,DE	
19	ADD HL,DE	
38AB	JR C,16534	
E1	POP HL	
C9	RET	
1604	LD D,4	
CD6B08	CALL 2155	
C9	RET	

### 2068 version

Listing 3 and 4 contain a version of PABLO PIXEL-0 for T/S 2068 owners. There are a few enhancements in this version, made possible by the extended powers of the 2068 computer. Instead of storing our new characters in an array, we will store them in a table above RAMTOP and set the system variable pointing to the character table, to point to our new table (see line 125). Of course, we can have a screen display of our high-resolution picture. Also, when entering the codes for your printed picture, you are allowed the option of choosing separate ink and paper colors for display. The POKE in line 220 sets the system variable controlling the cursor mode into graphics. Your REM statement in line 1 should contain 63 characters after REM. After entering the program, enter as a direct command, GOTO 9000. This will load the MC into the REM statement, checking for typing errors. You may then delete lines 9000-9199. Save the program by entering as direct commands, CLEAR and SAVE "pablo" LINE 10.

The program operates basically the same as the ZX-81 version. There is the added option of saving a copy of the screen after having displayed your picture. It is possible to define a new character set or font and point the system variables to point to this new set. (See the example 6) You may wish to incorporate this font into other programs.

### example 6

**sinclair**

Listing 3

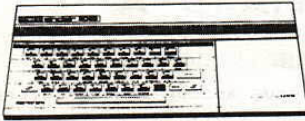

```

1 REM aaaaaaaaaaaaaaaaaaaaaa
aaaaaaaaabbbbbbbbbbbbbbbbbbb
bbbbbbbbbb
10 LET L=0: LET H=0
60 GO TO 600
100 CLS
105 PRINT AT 2,0;"Do you wish t
o set up a blank file?"
110 INPUT a$
115 IF CODE a$(>89 AND CODE a$(<
>121 THEN GO TO 600
120 PRINT AT 2,0;"How many char
acters do you wish to define?"
125 INPUT c: POKE 23728,c-INT
(c/256)*256: POKE 23729,c/256
: CLEAR 65367-(8*c)-384: LET
c=PEEK 23728+256*PEEK 23729
130 DIM i$(8,8): DIM b$(8,8): L
ET h=1: LET edit=0: DIM a$(10)
135 DIM d$(132): LET hcopy=0: LE
T option=0
145 LET chartable=65367-8*c-384

200 FOR f=1 TO c
202 PAPER 7: INK 0: BORDER 7: C
LS : DIM i$(8,8)
205 PRINT AT 0,0;"Plot out char
acter ";(f AND NOT edit)+(h AND
edit)
210 PRINT AT 20,0;d$;d$;AT 5,6;
"1";AT 21,1;"12345678";AT 4,7;"
12345678"
215 FOR a=1 TO 8
220 POKE 23617,2: INPUT i$(a,1
TO 8)
225 FOR b=1 TO 8
227 PRINT AT 20,0;d$;" 12345678
"

230 IF i$(a,1)="m" OR i$(a,1)="
M" OR CODE i$(a,1)=156 THEN GO
TO 600
235 IF i$(a,b)=CHR# 128 OR i$(a
,b)=CHR# 143 OR i$(a,b)=CHR# 32
THEN GO TO 250
240 PRINT AT a+4,7;"RE-ENTER"
245 GO TO 220
250 NEXT b
255 PRINT AT a+4,7;i$(a,1 TO 8)
: IF a<8 THEN PRINT TAB 6;a+1

260 NEXT a
265 PRINT AT 20,0;d$;d$;AT 20,0
;"Are you satisfied?"
270 POKE 23617,0: INPUT a$
275 IF CODE a$(>89 AND CODE a$(<
>121 THEN GO TO 335
280 FOR a=1 TO 8
290 FOR b=1 TO 8
295 LET b$(a,b)="1" AND i$(a,b
)=CHR# 143)+(0 AND (i$(a,b)=C
HR# 128 OR i$(a,b)=CHR# 32))
300 NEXT b
305 NEXT a
310 FOR p=1 TO 8
315 POKE chartable+((f-1 AND NO
T edit)+(h-1 AND edit))*8+(p-1
),VAL (CHR# 196+b$(p,1 TO 8))
320 NEXT p
322 IF edit THEN GO TO 600
325 NEXT f
330 GO TO 600

```

```

335 PRINT AT 20,0;d$;d$;AT 20,0
;"Do you wish to change individ
ual lines?"
340 INPUT a$
345 IF CODE a$(>89 AND CODE a$(<
>121 THEN GO TO 202
350 PRINT AT 20,0;d$;d$;AT 20,0
;"What line do you wish to chan
ge?"
355 INPUT a
360 PRINT AT 20,0;d$;d$;AT 20,0
;"working on line ";a;AT 21,0;"
12345678"
365 POKE 23617,2: INPUT i$(a,1
TO 8)
370 PRINT AT a+4,7;i$(a,1 TO 8)

375 GO TO 265
400 LET re=0: LET option=0: CLS
: INPUT "How many characters a
cross will you picture be? ";w:
IF w>32 THEN GO TO 400
405 INPUT "How many lines will
be in you picture? ";l
410 INPUT "Do you wish to input
paper and ink for each charac
ter? "; LINE z$: IF CODE z$=COD
E "y" OR CODE z$=CODE "Y" THEN
LET option=1
415 LET re=1: DIM p(1,w): IF op
tion THEN DIM a(2,l,w)
420 CLS : PRINT AT 2,0;"Enter c
ode numbers for new","character
set in the order you wish the
m to be displayed": IF z$="7" A
ND re THEN GO TO 435
425 FOR q=1 TO l
430 FOR r=1 TO w
435 IF q>l AND r>w THEN GO TO
600
440 PRINT AT 19,0;d$;d$;AT 20,0
;"Line "iq;" / Space "jr: INPUT
p(q,r)
445 IF p(q,r)>=0 AND p(q,r)<=c
THEN GO TO 465
455 PRINT AT 19,0;"Invalid inpu
t, re-enter!"
460 GO TO 440
465 IF option THEN INPUT "Pape
r? #";a(1,q,r): IF a(1,q,r)>9 O
R a(1,q,r)<0 THEN GO TO 465
470 IF option THEN INPUT "Ink?
#";a(2,q,r): IF a(2,q,r)>9 OR
a(1,q,r)<0 THEN GO TO 470
472 IF p(q,r)=0 THEN GO TO 600

475 NEXT r: NEXT q
480 INPUT "Paper color? #";pape
r: IF paper>9 OR paper<0 THEN
GO TO 480
485 INPUT "Border color? #";bor
der: IF border>7 OR border<0 TH
EN GO TO 485
490 INPUT "Ink color? #";ink: I
F ink<0 OR ink>9 THEN GO TO 49
0
500 BORDER border: PAPER paper:
INK ink: CLS
510 INPUT "Do you wish a hardco
py? "; LINE z$: IF CODE z$=CODE
"y" OR CODE z$=CODE "Y" THEN
LET hcopy=1
520 FOR a=1 TO l: FOR b=1 TO w
525 POKE 23606,(chartable+(p(a,
b)-1)*8)-INT ((chartable+(p(a,b
)-1)*8)/256)*256: POKE 23607,IN
T ((chartable+(p(a,b)-1)*8)/2
56)-1

```

```

530 IF PEEK 23689<3 THEN POKE
23606,0: POKE 23607,60
535 IF option THEN PRINT PAPER
R a(1,a,b); INK a(2,a,b);CHR# 3
2;
540 IF NOT option THEN PRINT C
HR# 32;: IF hcopy THEN LPRINT
CHR# 32;
542 IF NOT option AND PEEK 2368
9<4 THEN PRINT CHR# 8;: POKE 2
3606,(chartable+(p(a,b)-1)*8)-I
NT ((chartable+(p(a,b)-1)*8)/25
6)*256: POKE 23607,INT ((charta
ble+(p(a,b)-1)*8)/256)-1: PRI
NT CHR# 32;
543 IF option AND PEEK 23689<4
THEN PRINT CHR# 8;: POKE 23606
,(chartable+(p(a,b)-1)*8)-INT (
(chartable+(p(a,b)-1)*8)/256)*2
56: POKE 23607,INT ((chartable+
((p(a,b)-1)*8)/256)-1: PRINT
PAPER a(1,a,b); INK a(2,a,b);CH
R# 32;
545 NEXT b: PRINT
550 IF hcopy THEN LPRINT
555 NEXT a
560 POKE 23606,0: POKE 23607,60
: POKE 23692,23
565 PRINT #1;"Z=COPY M=MENU S
=SCREEN# SAVE"
570 IF INKEY$("<") THEN GO TO 5
60
575 IF INKEY$="s" OR INKEY$="S"
THEN GO TO 1000
580 IF INKEY$="z" OR INKEY$="Z"
THEN COPY
585 IF INKEY$("<")="m" AND INKEY$("<
")="M" THEN GO TO 575
590 LET hcopy=0
600 BORDER 1: PAPER 1: INK 9: C
LS : LET edit=0
605 POKE 23617,0
610 PRINT AT 2,0; BRIGHT 1;"***
* PABLO PIXEL-0 *****"
620 PRINT AT 4,4;"DEFINE CHARAC
TERS.....1";AT 6,4;"CONTINUE
DEFINITIONS....2";AT 8,4;"PICTU
RE CODING.....3";AT 10,4;"
PRINT OUT PICTURE.....4";AT 1
2,4;"SAVE.....5"
;AT 14,4;"RE-DEFINE CHARACTER..
...6";AT 16,4;"CONTINUE PICTURE
CODING.7";AT 18,4;"BIG-BITS...
.....8"
630 PRINT BRIGHT 1;AT 20,5;"EN
TER ONE OF THE ABOVE"
650 INPUT LINE z$
660 IF CODE z$<49 OR CODE z$>56
THEN GO TO 650
670 GO TO 650-(550 AND z$="1")-
(448 AND z$="2")-(250 AND z$="3
")-(150 AND z$="4")+(380 AND z$
="5")+(50 AND z$="6")-(230 AND
z$="7")-(20 AND z$="7" AND L=0
))+150 AND z$="8")
700 LET edit=1
710 CLS
720 PRINT AT 2,0;"Which charact
er do you wish to re-define? (
enter #)"
730 INPUT h
740 GO TO 202
800 CLS : DIM b(6,8)
805 INPUT "How many lines? (6 m
ax.) ";j
810 IF j<1 OR j>6 THEN GO TO 8
10
815 INPUT "How many across? (8
max.) ";k

```

```

820 IF k<1 OR k>8 THEN GO TO 8
20
830 PRINT AT 2,0;"Enter code nu
mbers in the order you wish the
m displayed."
835 FOR a=1 TO j
840 FOR b=1 TO k
845 PRINT AT 19,0;d#;id#;AT 20,0
;"Line ";a;" / Space ";b
850 INPUT b(a,b)
855 IF b(a,b)>=1 AND b(a,b)<=c
THEN GO TO 870
860 PRINT FLASH 1;AT 19,0;"Inv
alid input. Re-enter."
865 GO TO 850
870 NEXT b
875 NEXT a
900 PAPER 7: BORDER 7: INK 0: C
LS : PRINT #1;"Note pad is bein
g loaded. Z=COPY M=MEN
U"
902 LET note=64983: POKE 23659,
0
905 FOR a=1 TO 6: FOR b=0 TO 7
STEP 2: FOR d=1 TO 8
910 IF NOT b(a,d) THEN POKE no
te,0
915 IF b(a,d) THEN POKE note,P
EEK ((chartable+(b(a,d)-1)*8)+b
)
920 IF NOT b(a,d) THEN POKE no
te+1,0

```

```

925 IF b(a,d) THEN POKE note+1
,PEEK ((chartable+(b(a,d)-1)*8)
+b+1)
930 LET note=note+2
960 NEXT d: NEXT b: NEXT a
965 PRINT AT 0,0: RANDOMIZE US
R 26731
970 POKE 23659,2: POKE 26773,J#
32
980 IF INKEY*("<" THEN GO TO 9
80
985 IF INKEY*="z" OR INKEY*="Z"
THEN RANDOMIZE USR 26771
990 IF INKEY*("<"m" AND INKEY*("<"
M" THEN GO TO 985
995 GO TO 600
1000 REM save screens#
1010 INPUT "Picture title: ";a#
1020 SAVE a#SCREEN#: GO TO 600
1030 CLS : PRINT AT 10,0: FLASH
1;"please note that you will ha
ve to enter CLEAR ";PEEK 2373
0+256*PEEK 23731;" before lo
ading this program after s
aving!
"
1035 INPUT "What is the title? "
;a#
1040 SAVE a# LINE 2000

```

```

1045 SAVE a#CODE chartable,c#8
1050 GO TO 600
2000 LOAD a#CODE
2010 GO TO 600
9000 LET address=26715
9100 LET a#="8084888C8185898D828
68A8E838788BF21D7FD06C0C5060456
235E23E5AFCB1217CB1217CB1317CB1
317215868856F7ED710EAE1C110DEC9
F306C0CD050AC9"
9105 IF LEN a#("<126 THEN PRINT
"Error in A# please correct.":
STOP
9110 FOR X=1 TO LEN a#-1 STEP 2
9115 POKE address+INT ((X-1)/2),
(CODE a#(X)-(48 AND CODE a#(X)<
58)-(55 AND CODE a#(X)>64))*16+
CODE a#(X+1)-(48 AND CODE a#(X+
1)<58)-(55 AND CODE a#(X+1)>64)
9120 NEXT X
9125 LET check=0: FOR x=0 TO 62:
LET check=check+PEEK (26715+x)
: NEXT x
9130 IF check("<7488 THEN PRINT
"Look for errors in A#." : STOP
9135 IF check=7488 THEN PRINT "
Machine code checks out."

```

#### Listing 4

Address	Op code (hex)	Mnemonics
26731	21D7FD	LD HL,64983
26734	06C0	LD B,192
26736	C5	PUSH BC
26737	0604	LD B,4
26739	56	LD D,(HL)
26740	23	INC HL
26741	5E	LD E,(HL)
26742	23	INC HL
26743	E5	PUSH HL
26744	AF	XOR A
26745	CB12	RL D
26747	17	RLA
26748	CB12	RL D
26750	17	RLA
26751	CB13	RL E
26752	17	RLA
26753	CB13	RL E
26754	17	RLA
26757	215B68	LD HL,26715
26760	85	ADD A,L
26761	6F	LD L,A
26762	7E	LD A,(HL)
26763	D7	RST 10h
26764	10EA	DJNZ,26744
26766	E1	POP HL
26767	C1	POP BC
26768	10DE	DJNZ,26736
26770	C9	RET
26771	F3	DI
26772	06C0	LD B,192
26774	CD050A	CALL 2565
26777	C9	RET

USE PABLO PIXEL-0 AND SEND US YOUR ARTWORK!

TIME DESIGNS will publish examples of computer "art" using the PABLO PIXEL-0 program supplied in this issue, in upcoming future issues. We may publish yours! Send artwork from either T/S 1000 or T/S 2068.

send to: TIME DESIGNS  
29722 Hu!t Rd.  
Colton, OR 97017

# A GRAPHICS PROBLEM for the T/S2068

A "SERIOUS" GRAPHICS DISPLAY FOR THE 2068 AND 2040 PRINTER

by Dick F. Wagner  
Canby, Oregon



One of my pet beefs with many computer programmers is their lack of concern for identifying the basis for their programs. The display of the formulas/equations used, would help the user decide if the program is indeed the one needed for his (or her) calculations. It is often not easy to pick this information out of the program because of the way the programmer had to chop up the formula/equation. Also there should not be the need to spend a lot of time trying to identify the information needed.

The following program is substantiated as to formulas. This makes it easy to substitute as you wish. However the problem is complex in that several systems are involved in developing a problem display. The formal graph with x and y axis, notations and scales provide an example for similar displays. The derivations for generating an equilateral triangle as well as drawing an inner and outer circle touching the triangle shows the steps. The chart coordinates have suitable divisions marked off, as well as enhancing every 5th division. The end product, instead of just displaying a triangle and 2 circles, shows the result of calculating a problem with interpretive results.

The first step is to draw the x and y axis, scales, divisions and headings. The radius of the outer circle is to be 40 inches. Use a scale of one pixel as one inch. Therefore, we need to provide for a figure 80 by 80. For a nice balance, place the circle center at 95 (x axis) and 80 (y axis). To allow space for x and y axis data place the x axis 20 and the y axis at 25. Position markers every 10 pixels (inches) and enhance every 5th mark. Remember that all positions are with respect to 0,0 for PLOT (bottom left corner) and 0,0 for PRINT (top left corner).



GRAPHIC PLOTS OF  
AN EQUILATERAL TRIANGLE  
WITH INNER AND OUTER  
CIRCLES  
D.F.W. 2/85

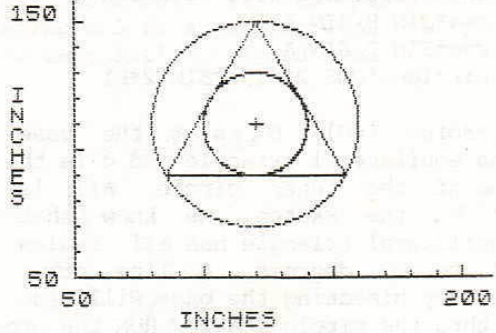

Lines 10-190 generate the axis, markers, axis numbers and axis names. Many lines include a printer correction factor of 1.24 (Timex 2040 Printer). This is necessary to produce a symmetrical image. After all, who wants to excuse his (or her) equipment for making egg-shaped circles and non-equilateral triangles?

To review the derivation of the correction factor, just DRAW a square of good size, and make a printer copy. Measure the height and width (use a decimal or metric scale). The ratio of these dimensions is the correction factor. Now re-draw the square, using this multiplier. For example, assume the square was drawn with PLOT 30,30:DRAW 80,0: DRAW 0,80: DRAW -80,0: DRAW 0,-80. For the 2040 Printer, you would change the 1st and 3rd DRAW to 1.24\*80,0 and -80\*1.24,0. Check your printer to see if it is the same.

Lines 45-110 put in the markers on the x axis, and lines 120-190 put in the y axis markers. RUN the program from 10-190 and confirm proper display. CLS and the "graph paper" is now ready to plot the 3 figures. It is now time to calculate the dimensions for the figures and decide where to place them. Remember that we are going to have a display with measuring capability of the finished figures.

Calculations start with determining the sides of the equilateral triangle from one dimension, the radius of the outer circle. That has been given as 40 inches (3rd paragraph). Key in lines 395-470. DELETE later if desired. This part will draw a right triangle (any scale) and from the hypotenuse (the radius of the outer circle), we can determine  $\frac{1}{2}$  the base and the radius of the inner circle.

These formulas will be used:

$$b = a \cdot \sin B / \sin A$$

$$c = a \cdot \sin C / \sin A$$

$$\text{circle} = r \cdot \cos 2 \cdot \pi, r \cdot \sin 2 \cdot \pi$$

a is radius (40), b is  $\frac{1}{2}$  the base of the equilateral triangle and c is the radius of the inner circle. All is shown on the sketch. We know that an equilateral triangle has all angles equal to 60 degrees. A line drawn vertically bisecting the base will also pass thru the circle center. RUN the program from 395, and display the triangle along with the calculations. Angle B may not be evident, so consider B as  $\frac{1}{2}$  of one third of 360 degrees.

#### TRIANGLE CALCULATIONS

b=1/2 base, c=radius center to base, a=radius circle (given as 40).

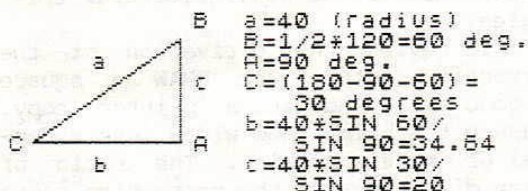

There are all the dimensions required.

Lines 200-320 draw the 3 figures with center at 95,80.

Lines 330-370 put in a title, initials (yours) and date.

I think you will agree that our computers can produce a product that takes it out of just a visual display.

5 REM Lines constructed at right angle and at the midpoint of each side of an equilateral triangle will intersect. This point will be the center of a circle that will touch each side and also a circle will touch each corner of the triangle.  
10 PLOT 25\*1.24,20: DRAW 0,145  
: PLOT 25\*1.24,20: DRAW 200,0

```

20 PRINT AT 21,10;"INCHES"
30 PRINT AT 10,0;"I";AT 11,0;"N";AT 12,0;"C";AT 13,0;"H";AT 14,0;"E";AT 15,0;"S"
35 PRINT AT 20,3;"50";AT 20,26;"200"
40 PRINT AT 19,1;"50";AT 5,0;"150"
45 FOR N=25*1.24 TO 220 STEP 10*1.24
50 FOR A=20 TO 22
60 PLOT N,A
70 NEXT A: NEXT N
80 FOR N=25*1.24 TO 220 STEP 50*1.24
90 FOR A=22 TO 24
100 PLOT N,A
110 NEXT A: NEXT N
120 FOR M=20 TO 150 STEP 10
130 FOR B=25*1.24 TO 27*1.24
140 PLOT B,M
150 NEXT B: NEXT M
160 FOR M=20 TO 150 STEP 50
170 FOR B=27*1.24 TO 29*1.24
180 PLOT B,M
190 NEXT B: NEXT M
200 PLOT 95*1.24,60
210 DRAW 60,28*.5*1.24,0
220 DRAW -34.64*1.24,60
230 DRAW -34.64*1.24,-60
240 DRAW 34.64*1.24,0
250 REM circle center is 95,80
270 PLOT 95*1.24,80-2: DRAW 0,4
: PLOT (95-2)*1.24,80: DRAW 6,0
290 FOR A=0 TO 2*PI STEP PI/120
300 PLOT 95*1.24+40*1.24*COS A,80+40*SIN A
310 PLOT 95*1.24+20*1.24*COS A,80+20*SIN A
320 NEXT A
330 PRINT AT 0,11;"GRAPHIC PLOT S OF"
340 PRINT AT 1,8;"AN EQUILATERA L TRIANGLE"
350 PRINT AT 2,9;"WITH INNER AN D OUTER"
360 PRINT AT 3,15;"CIRCLES"
370 PRINT AT 4,18;"D.F.W. 2/85"
375 COPY
380 PAUSE 4e4
390 CLS
395 PRINT "TRIANGLE CALCULATION S: PRINT " b=1/2 base, c=radius center to base, a=radius circle (given as 40)."
400 PLOT 20,20: DRAW 70,0: DRAW 0,40: DRAW -70,-40
410 PRINT AT 19,1;"C";AT 19,12;"A";AT 13,12;"B"
420 PRINT AT 20,6;"b";AT 16,12;"c";AT 15,6;"a"
430 PRINT AT 13,15;"a=40 (radius)";AT 14,15;"B=1/2*120=60 deg.";AT 15,15;"A=90 deg.";AT 15,15;"C=(180-90-60)=";AT 17,16;" 30 degrees"
440 PRINT AT 18,15;"b=40*SIN 60/SIN 90=34.64"
450 PRINT AT 19,15;"c=40*SIN 30/SIN 90=20"
460 PRINT AT 20,15;"c=40*SIN 30/SIN 90=20"
470 PRINT AT 21,15;"c=40*SIN 30/SIN 90=20"
480 COPY

```

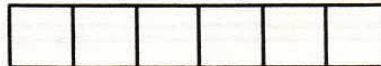
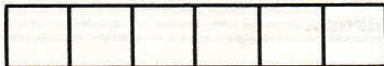

# ANOTHER LOOK AT 2068 GRAPHICS

## MORE OR LESS

by Paul Bingham

Listings #1 and #2 are shown to illustrate but one point. Both are graphically interesting, though this was not my full intention by including them.

Often what is most important when one does mathematically generated graphics is SPEED. Many take the 2068 the better part of an hour to produce...a long time to wait if one is testing and debugging formulas. One common trick is to change STEP values in FOR/NEXT loops to larger numbers. This lets a programmer "skip the detail" and more quickly get an idea of the general outcome. For the final version such values can be altered back so as to show the detail again.

I have found, however, that we tend to overwork our computers when generating graphic displays. The T/S 2068 knows no fatigue. It will calculate  $\cos .4$  five thousand times during a graphic without a complaint. But couldn't the value of  $\cos .4$  (.92106099) just as easily have been plugged in and thus saved some TIME plotting the graphic?

The more calculations the 2068 is forced to do each go, the slower and less appealing our graphic is to watch. Listing #1A produces a "bouncing ball". Listing #1B does exactly the same thing only less Work. Note the math in lines 180 and 190 of listing #1A have been reduced to line 20 of listing #1B. All the variable calculations in lines 10, 20, and 30 of #1A were also eliminated. These should both be run and compared for speed. Listing #1B will go even faster if line 30 is changed to read simply: PLOT x,y.

Listings #2A and #2B are mathematically much more complex. Again both produce the same sort of graphic. Listing #2A abounds in variables set and is replete with other formula "fat". Most certainly the formulas in this listing should be worked through and understood by the programmer. In the final version such

length is of no use to the computer, simply more code it must wade through. Listing #2B is a version with nearly every slow calculation trimmed down.

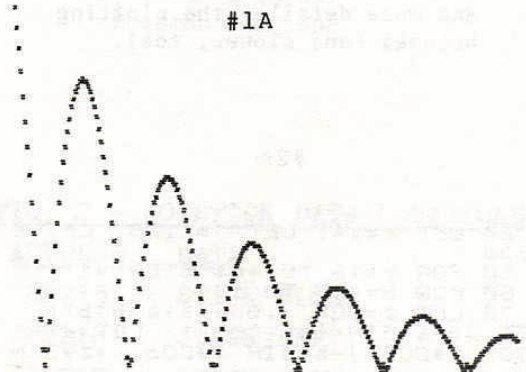

```
1 REM          BOUNCING BALL
10 LET xm=254: LET ym=174: LET
h=174
20 LET w=PI/40: LET d=90*PI/18
30 LET k=.01
170 FOR n=0 TO xm-10
180 LET yn=h*SIN (w*n+d)*EXP (-
k*n)
190 LET yn=ABS (yn)-3
200 PLOT n+10,yn: PLOT n+10,yn+
1: PLOT n+11,yn: PLOT n+11,yn+1
210 NEXT n
```

#1B

```
1 REM          BOUNCING BALL
10 FOR x=0 TO 253
20 LET y=174*SIN (.0785*x+1.57
)*EXP (-.01*x)
30 PLOT x,y: PLOT x+2,y: PLOT
x+1,y-1: PLOT x+1,y+1
40 NEXT x
```

Listing #2B is a fun one for experimentation. The slightest variation will cause differing outcomes. The beauty and excitement can only be achieved through experimenting, but some examples include:

- 1) Changing the value multiplied by z in line 120 adjusts the height of the topography-- .3 is flatter, .8 is steeper, 2.0 is pretty strange.
- 2) The value 600 shown in lines 100 and 120 can be increased for larger scale, decreased for smaller.
- 3) The value for b in line 90 is negative. The more negative it becomes the more exaggerated the right portion of the display becomes.
- 4) As discussed earlier, a smaller STEP value in line 60, the closer and more detailed the plotting becomes (and slower, too).

#2B

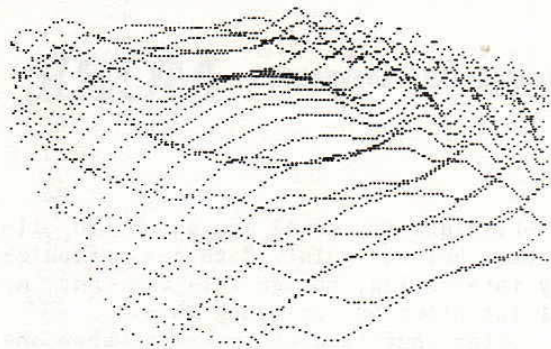

#2A

```

20 LET t=.4: LET j=1.25: LET e
=600
50 FOR a=19 TO -44 STEP -1
60 FOR b=-35 TO 16
70 LET z=cos (.06*(a*a+b*b)):
LET w=-a*sIN t+b*cos t: LET d=-a
*cos t*cos j-b*sIN t*cos j+z*sIN
j
100 LET h=80-a*sIN j*cos t-b*sI
N j*sIN t-z*sIN j
110 LET x=124-e*(w/h)
120 LET y=96+e*(d/h)
130 IF y>176 OR y<0 OR x>255 OR
x<0 THEN GO TO 200
140 PLOT x,y
200 NEXT b
210 NEXT a

```

```

1 REM          2068 CRATER
10 BORDER 1: PAPER 1: INK 7
20 LET q=-4: CLS
30 FOR a=23 TO -16 STEP -1.6
40 IF a>5 THEN LET q=q-1.7
50 IF a<5 THEN LET q=q+1
60 FOR b=q TO 15 STEP .3
70 LET z=cos (.06*(a*a+b*b))
90 LET h=80-a*.9-b-z
100 LET x=124-600*((-a*.4+b*.9)
/h)
110 IF x>255 OR x<0 THEN NEXT b
120 PLOT x,96+600*((-a*.3-b*.1+
z*.7)/h)
130 NEXT b
140 NEXT a

```

One might now take a look back through some old terribly slow graphic programs laying around. One will be amazed at the excess work we have been forcing out of our 2068s. Next time we will look into some even more interesting graphic ideas.

### 3D TUNNEL

For The 2068

```

10 PRINT INK 2; AT 2,10; "3D TUN
NE"
20 FOR X=70 TO 1 STEP -2
30 CIRCLE X,X,X
40 NEXT X
50 CLS
60 GO TO 10

```





**FIG. 3 - MACHINE CODE LOADER**

```

1 REM XXXXXXXXXXXXXXXXXXXXXXXXXXXX
XXXXXXXXXXXXXXXXXXXXXXXXXXXXXXXXXX
XXXX
10 FOR n=26715 TO 26773
20 READ d: POKE n,d
30 NEXT n
40 DATA 0,0,0,0,0,33,91,104,1,
0,5,113,35,15,252,52,14,211,245,
1,246,2,237,120,43,203,127,32,2,
54,1,43,203,71,32,2,54,1,43,203,
79,32,2,54,1,43,203,87,32,2,54,1,
43,203,95,192,54,1,201

```

Lines 10-40 of the loader can be DELETED and the remaining 1 REM machine code line can be SAVED to be later MERGED with any program that is being up-graded to joystick control.

At the point in a program where joystick information is needed, address #26736 is POKED with the desired joystick's no. (1-LEFT; 2-RIGHT) and the routine is called at 26720.

By PEEKING addresses 26715-26719, the sticks' position and button status are obtained.

The following program is a typical example of how the routine may be used to move a single character around the screen with a joystick. The program will stop when the "fire" button is pressed.

**FIG. 4 - EXAMPLE PROGRAM**

```

1 REM ?????? ! h????a# → the
  remainder is unlistable

10>LET x=26715: LET vert=10: L
ET horiz=15
20 PRINT AT vert,horiz;" "
30 RANDOMIZE USA 26720: REM **
the right stick is selected**
40 LET verticle=vert+PEEK (x+2)
)-PEEK (x+3)
50 LET horizontal=horiz+PEEK x
)-PEEK (x+1)
60 IF verticle<0 OR verticle>2
1 THEN GO TO 30
70 IF horizontal<0 OR horizont
al>31 THEN GO TO 30
80 PRINT AT verticle,horizonta
l;"#"
90 LET vert=verticle: LET hori
z=horizontal
100 IF PEEK (x+4)=1 THEN STOP
110 GO TO 20

```

Fig. 5 is the OP CODE listing for the 1 REM routine.

**FIG. 5 - OP CODE LISTING**

00715	00	NOP
00716	00	NOP
00717	00	NOP
00718	00	NOP
00719	00	NOP
00720	215B68	LD HL,26715
00721	010005	LD BC,1280
00722	71	LD (HL),C
00723	23	INC HL
00724	10FC	DJNZ 26726
00725	3E0E	LD A,14
00726	D3F5	OUT (245),A
00727	01F602	LD BC,758
00728	ED78	IN A,(C)
00729	2B	DEC HL
00730	CB7F	BIT 7,A
00731	2002	JR NZ,26745
00732	3601	LD (HL),1
00733	2B	DEC HL
00734	CB47	BIT 0,A
00735	2002	JR NZ,26753
00736	3601	LD (HL),1
00737	2B	DEC HL
00738	CB4F	BIT 1,A
00739	2002	JR NZ,26760
00740	3601	LD (HL),1
00741	2B	DEC HL
00742	CB57	BIT 2,A
00743	2002	JR NZ,26767
00744	3601	LD (HL),1
00745	2B	DEC HL
00746	CB5F	BIT 3,A
00747	C0	RET NZ
00748	3601	LD (HL),1
00749	C9	RET

## 2068 COLOR DEMO

by Edwin S. Salter  
Milton, Florida

```

20 REM T/S 2068 COLOR DEMO
30 REM E SALTER 1-20-85
50 RANDOMIZE 0
55 BORDER INT (RND*7)
60 FOR a=0 TO 150: INK INT (RN
D*7)
70 CIRCLE 127,87,a-67: PLOT a,
a: DRAW 255-a-a,0: DRAW 0,175-a-
a: DRAW -255+a+a,0: DRAW 0,-175+
a+a
80 NEXT a
90 PAUSE 50: GO TO 55
100 REM GOTO 9999 to list progr
am
9999 BORDER 7: PAPER 7: INK 0: C
LS : LIST

```

```

1 PEM *****
2 PEM *BILLY'S SLOT MACHINE*
3 PEM *****
4 INK 1
5 LET P=0
6 PAPER 6
7 BORDER 6
8 C1S
9 LET S=500
10 GO SUB 1000
11 PRINT AT 1,28;S
12 PAUSE 150
13 LET A$="CHERRYLEMON PLUM ORANGE BELL -BAR-CHERRY"
14 PAPER 6
15 GO TO 21
16 FOR J=1 TO 22
17 PRINT AT 7,20;" "
18 PRINT AT 10,J;" "
19 PRINT AT 11,J;" "
20 PRINT AT 12,J;" "
21 PRINT AT 20,1;"3 BAR OR BELL=JACKPOT"
22 NEXT J
23 DIM B$(3,6)
24 FOR J=1 TO 3
25 LET B$(J)=A$(1+6*INT (RND *7) TO 42)
26 IF B$(J)="CHERRY" THEN PAPER 2
27 IF B$(J)="LEMON" THEN PAPER 6
28 IF B$(J)=" PLUM " THEN PAPER 3
29 IF B$(J)="ORANGE" THEN PAPER 2: INK 6
30 IF B$(J)=" BELL " THEN PAPER 0: INK 6
31 IF B$(J)=" -BAR-" THEN PAPER 7: INK 0
32 PRINT AT 11,7*J-5;B$(J)
33 BEEP .05,15
34 PAPER 6: INK 1
35 NEXT J
36 PLOT 214,47
37 DRAW 0,55: DRAW 2,0: DRAW 0,23: DRAW -8,0: DRAW 0,-23: DRAW 2,0: DRAW 0,-55
38 GO SUB 2000
39 PRINT AT 7,21;"DEPOSIT 2 BITS-->"
40 PRINT AT 7,21; FLASH 1;"D"
41 IF INKEY$="d" OR INKEY$="D" THEN PRINT AT 7,21;" "
42 GO TO 83
43 PRINT AT 6,28;"PULL": PRINT AT 7,27;"<----"
44 PRINT AT 7,26; FLASH 1;"P"
45 LET S=S-25: PRINT AT 1,28;S
46 IF INKEY$="p" OR INKEY$="P" THEN GO TO 91
47 GO TO 89
48 PRINT AT 5,26;" " AT 6,26;" " AT 7,26;" " AT 8,26;" " AT 9,
261;" " AT 10,261;" " AT 11,261;" " AT 12,261;" " AT 13,261;" " AT 14,261;" "
49 GO TO 20
1000 PRINT
1001 PLOT 0,4
1002 DRAW 192,0
1003 DRAW 0,148
1004 DRAW -192,0
1005 DRAW 0,-148
1006 PLOT 192,24
1007 DRAW 8,0
1008 DRAW 0,40
1009 DRAW -8,0
1010 PLOT 200,40
1011 DRAW 12,0
1012 PLOT 200,48
1013 DRAW 12,0
1014 CIRCLE 212,44,5
1015 PLOT 210,49
1016 DRAW 0,55
1017 PLOT 214,49
1018 DRAW 0,55
1019 DRAW 2,0
1020 DRAW 0,23
1021 DRAW -8,0
1022 DRAW 0,-23
1023 CIRCLE 172,116,14
1024 PLOT 6,70
1025 DRAW 180,0
1026 DRAW 0,28
1027 DRAW -180,0
1028 DRAW 0,-28
1029 PRINT AT 4,5;"BILLYS SLOT"
1030 PRINT AT 5,7;"MACHINE"
1031 PRINT AT 14,4;"2 CHERRY PAYS 2"
1032 PRINT AT 15,4;"3 CHERRY PAYS 5"
1033 PRINT AT 16,4;"2 PLUM PAYS 5"
1034 PRINT AT 17,4;"3 PLUM PAYS 10"
1035 PRINT AT 18,4;"2 ORANGE PAYS 5"
1036 PRINT AT 19,4;"3 ORANGE PAYS 10"
1037 PRINT AT 1,15;"YOU NOW HAVE"
1040 RETURN

```

## 2068 PROGRAM

# SLOT MACHINE

by Bill Gunter

REAL LAS VEGAS STYLE CASINO ENTERTAINMENT!  
The program is a slot machine which plays 25 cent pieces, and keeps track of your winnings and losses (it even plays a little fanfare if you hit the jackpot). The odds ought to be pretty close to Nevada odds, and should keep the children quiet for hours. It is important to get the spacing just right in line 15, since the "fruit" which appear in the slot machine windows are "slices" of the character string "A\$". (EDITOR'S NOTE: this listing was made with a printer that doesn't use "0" for zero. So be careful when entering numbers in this program.)

": PR

```

2010 IF B$(1)=B$(2) AND B$(1)="CHERRY" THEN LET P=50: PRINT AT 1,1; FLASH 1;"YOU WIN "
2011 IF B$(1)=B$(2) AND B$(1)=B$(3) AND B$(1)="CHERRY" THEN LET P=125: PRINT AT 1,1; FLASH 1;"YOU WIN "
2012 IF B$(1)=B$(2) AND B$(1)=" PLUM " THEN LET P=125: PRINT AT 1,1; FLASH 1;"YOU WIN "
2013 IF B$(1)=B$(2) AND B$(1)=B$(3) AND B$(1)=" PLUM " THEN LET P=250: PRINT AT 1,1; FLASH 1;"YOU WIN "
2014 IF B$(1)=B$(2) AND B$(1)="ORANGE" THEN LET P=125: PRINT AT 1,1; FLASH 1;"YOU WIN "
2015 IF B$(1)=B$(2) AND B$(1)=B$(3) AND B$(1)="ORANGE" THEN LET P=250: PRINT AT 1,1; FLASH 1;"YOU WIN "
2016 IF B$(1)=B$(2) AND B$(1)="LEMON" THEN PRINT AT 1,1; FLASH 1;"SORRY, NO WIN"
2017 IF B$(1)=B$(2) AND B$(1)=B$(3) AND B$(1)=" -BAR-" THEN PRINT AT 1,1; FLASH 1;"JACKPOT - $10": LET P=1000: GO SUB 4000
2018 IF B$(1)=B$(2) AND B$(1)=B$(3) AND B$(1)=" BELL " THEN PRINT AT 1,1; FLASH 1;"JACKPOT - $10": LET P=1000: GO SUB 4000
2019 LET S=S+P
2020 PRINT AT 1,28;" "
2021 PRINT AT 1,28;S
2022 LET P=0
2025 IF S=0 THEN GO TO 3000
2040 PAUSE 75
2050 PRINT AT 1,1;" "
2060 RETURN
3000 PRINT AT 1,0;"YOU ARE BUSTED-FOR REPLAY HIT "
3010 IF INKEY$="R" THEN RUN
3020 GO TO 3010
4000 BEEP .2,-3: BEEP .2,2: BEEP .2,6: BEEP .4,9: BEEP .2,6: BEEP .8,9
4010 RETURN

```

# PROGRAMS

## JOYSTICK

```

2 REM ** JOYSTICK
  DEMONSTRATION
  by
  Warren Fricke
3
5 LET C=10: LET L=10
10 PRINT AT L,C;"*"
15 LET LL=L: LET CC=C
20 LET S= STICK (1,1)
25 LET FB= STICK (2,1)
30 LET C=C+(C<31 AND (S=8 OR S=
  9 OR S=10))-(C>0 AND (S=4 OR S=
  5 OR S=6))
35 LET L=L+(L<21 AND (S=2 OR S=
  6 OR S=10))-(L>0 AND (S=1 OR S=
  5 OR S=9))
40 PRINT AT 10,14;"FIRE" AND
  FB=1
45 PAUSE 5
50 PRINT AT LL,CC;" " AND (LL<
  >L OR CC<>C)
55 GO TO 10
  
```

In this demo routine it is assumed that the joystick is plugged into the port on the player's left. Refer to Lines 20 and 25. RUN the routine. A "\*" will appear at Row 10, Column 10. This asterisk can be moved in any one of eight directions by positioning the joystick. The action of the GOTO loop is fairly fast (hence Line 45), and the asterisk may repeat the movement too quickly. If so, a deliberate stepping action can be introduced by a line like...

```
17 IF STICK (1,1) 0 THEN GOTO 17
```

Now we must jog the paddle for each step. We can't use PAUSE 0 to step the action as STICK can not release PAUSE like a key-stroke does.

In this demonstration routine the fire button will print the word FIRE near the center of the screen when pressed. You can erase the word by running the asterisk thru it.

The conventional joystick produces a diagonal motion if the paddle is so positioned, but there is a drawback. The first step, before a diagonal one is taken, must be either vertical or horizontal. This is an inherent flaw in joystick design. To get a diagonal motion, two electrical contacts must be closed inside the joystick, and it is generally not possible to close them simultaneously. Hence, the motion starts off either horizontally or vertically, depending upon which switch closed first.

Warren Fricke

## ALPHABETIZER

by Earl Dunnington

This "ALPHABETIZER" routine will work with all Timex computers. Information on converting the program for the 2068 is contained in the REM statements and uneven lines. To SAVE this program, use "GOTO 265".

```

1 REM ZX81,TS1000,1500,2068 "
  ALPHABETIZER"-BY EARL DUNNINGTON
2 REM BASIC COMMANDS PECULIAR
  TO THE ZX81,TS1000 AND 1500 PRO-
  GRAM, HAVE UNEVEN LINE NUMBERS
  FOR EASE IN CONVERTING TO 2068
10 PRINT " INPUT <NUMBER OF EN-
  TRIES>," THEN PRESS ENTER"
15 FAST
20 INPUT A
30 CLS
40 PRINT " INPUT <MAXIMUM NUMB
  ER OF LET- TERS IN AN ENTRY>","
  THEN PRESS ENTER"
50 INPUT B
60 CLS
70 DIM A$(A,B)
80 FOR I=1 TO A
90 PRINT " <TYPE AN ENTRY>"," "
  THEN PRESS ENTER"
100 INPUT A$(I)
110 CLS
120 NEXT I
130 LET X=0
140 LET X=X+1
150 IF X>A THEN STOP
160 IF A$(X)="ZZ" " THEN GOT
  O 140
170 FOR Y=1 TO A
180 IF A$(Y)<A$(X) THEN LET X=Y
190 NEXT Y
200 LPRINT A$(X)
205 REM FOR THE 2068 CHANGE
  THIS LINE TO READ:
205 POKE 23692,100
215 PRINT AT 21-INT (B/32),0;A$(
  X)
220 PAUSE 50
225 FOR N=1 TO INT (B/32)+1
235 SCROLL
245 NEXT N
250 LET A$(X)="ZZ" "
260 GOTO 130
265 SAVE "ALPHABETIZ"
275 GOTO 10
285 REM TO SAVE PROGRAM USE
  < GOTO 265 >
295 REM FOR THE 2068:
  DELETE LINE 15
  CHANGE LINE 215 TO READ:
  215 PRINT AT 21,0;A$(X)
  DELETE LINE 225
  CHANGE LINE 235 TO READ:
  235 LET S=USR 2361
  DELETE LINE 245
  CHANGE LINE 265 TO READ:
  265 SAVE "ALPHABETIZ" LINE 10
  DELETE LINE 275
  
```

# Entering and Recalling Text

## in Machine Code

By Dennis Jurries

This subroutine will allow the user to enter up to 277 characters into machine code and recover them at will. The routine consists of four parts. The first part is the machine code loader program.

```

10 FOR x=55501 TO 55530
20 READ z: POKE x,z
30 NEXT x
40 DATA 62,0,205,48,18,225,70,
55,229,33,133,215,126,35,254,120,
,56,250,16,248,126,35,254,126,20
0,215,24,248,201,205,205,216,1,2
01

```

RUN the above program then DELETE it. The second part consists of six lines that allow the text you input into machine code, to be recovered.

```

10 FOR x=1 TO z
20 POKE 55533,x
30 RANDOMIZE USR 55530
40 PAUSE 0
50 NEXT x
60 STOP

```

The third part of the routine allows the user to put text into machine code. Once the user puts the text in and tests it, then this part may be deleted.

```

100 LET z=1: LET J=55224: LET a
$=""
110 PRINT "Input text (limit 32
characters if you want to print
text on the 24th line only). Pr
ess enter when finished with t
ext."
120 PRINT
130 GO SUB 300
140 INPUT a$
150 IF LEN a$>=55500-J THEN PRI
NT AT 0,0;"Text too long. Input
text.": CLS : LET J=J-LEN a$: LE
T z=z-1: GO TO 110

```

```

160 FOR i=1 TO LEN a$
170 POKE J,CODE a$(i)
180 IF J<55500 AND i=LEN a$ THE
N POKE J+1,128
190 IF J<55500 AND i=LEN a$ THE
N LET J=J+1
200 IF J<55500 THEN LET J=J+1
210 NEXT i
220 LET z=z+1
230 GO SUB 400
240 LET z=z-1
250 STOP
300 PRINT "TEXT #";z;" " ";277
-LEN a$;" characters remaining."
310 RETURN
400 PRINT
410 PRINT "More text? (y/n)"
420 PAUSE 0
430 IF INKEY$="y" OR INKEY$="Y"
THEN CLS : GO TO 110
440 RETURN

```

The above is set up to print on the 24th line. Several different messages can be run if you add a line, 45 CLS. If you wish to print text from the top of the page, then POKE 55502,2. To change back to the 24th line, POKE 55502,0.

The following is the OP CODE for the machine code routine, that was entered in part one above. This is the fourth part of the subroutine.

```

55501 LD A,0
55503 CALL 4556
55505 POP HL
55507 LD B,(HL)
55508 INC HL
55509 PUSH HL
55510 LD HL,55223
55513 LD A,(HL)
55514 INC HL
55515 CP 128
55517 JR C,55513
55519 DJNZ B,55513
55521 LD A,(HL)
55522 INC HL
55523 CP 128
55525 RET Z
55526 RST 16
55527 JR 55521
55529 RET
55530 CALL 55501
55533 01
55534 RET

```

To save the machine code routine, type SAVE "mssg" CODE 55224,350.

# SCREEN DISPLAY STORAGE AND MEMORY RELOCATE

By Dennis Jurries

The following is a routine that will work on the TS 2068, and with address modifications, on the TS 1000. You can save screen displays, or use it to relocate a program in memory from one address to another. The program as it is written here, will allow three screen displays to be stored and recalled in approximately 0.04 seconds.

The screen display on the TS 2068 is located at address 16384 and takes up 6912 bytes of memory.

Machine code loader and MC

```
5 CLEAR 44500
10 FOR I=44510 TO 44620
15 READ X: POKE I,X: NEXT I
20 DATA 33,0,64,17,86,174,114,6,
33,86,174,17,0,64,1,0,27,207,
178,201
```

RUN and DELETE 5,20

If you wish to allow space for more, the two 174's in line 20 will have to be reduced by 27 for each extra screen display, and the addresses in lines 5 and 10 will have to be reduced by 6912 for each extra screen. Be sure to check to see if you have enough memory to add the extra screens.

LOAD in or design your first screen display. Type RAND (single key) USR 44610 and press ENTER to store the first screen. POKE 44615, 201 for the second screen display set up.

LOAD in or design your second screen display. Press RAND USR 44610 and ENTER to store the second screen. To set up for the third screen display, type POKE 44615,228.

LOAD in or design your third screen display. Press RAND USR 44610 and ENTER to store the third screen. The USR addresses will change by 6912 for each extra screen display over the three set up here.

To recover your screen displays:

POKE 44620,174 for screen #1

POKE 44620,201 for screen #2

POKE 44620,228 for screen #3

and press RAND USR 44618

For any extra screens, change address 44618 to 6912 less than 44618 for each extra screen, and the same for address 44620. The value of the number poked into address 44620 changes by 27 for each screen, and will also do so for any extra screen displays.

To save your screen displays, press SAVE "name" CODE 44610,2075 6. If more than three screen displays are to be saved, then change the first number after the CODE to the new starting address, and add 6912 times the number of screens in excess of three to the second number.

OP-CODES for machine code

```
44610 LD HL,16384
44613 LD DE,44630
44616 JR 0
44618 LD HL,44530
44621 LD DE,16384
44624 LD BC,6912
44627 LDIR
44629 RET
```

## COMPUTER PROJECT

# MAKE A STATIC DISCHARGE BRACELET

The computer chip manufacturing industry has spent millions in building specially designed facilities. They are 99.9% free from common static electricity, which can destroy certain IC chips that are static sensitive, in an such a facility might have equipment that removes static from the environment, specially treated floor and work services, and the employees wear certain garments and shoes. While an electronic hobbyist cannot afford such state of the art apparatus in his own home workshop, the hazards of static electricity discharge are every bit as real.

Zapped computer chips such as microprocessors and logic chips, ROM, EPROMs, CMOS and MOS chips are not much fun, and certainly quite costly to replace. Although seasoned experimenters may rarely come across many problems in this area, special handling procedures need to be observed. This usually entails one or more of the following:

1. Carefully open up the computer's case, and use minimal handling around the circuit board, chips, and other internal parts. Power should always be off.
2. Right before removing or installing a computer chip, discharge the static electricity that has built up in your body by touching a grounded object (i.e. drain pipes, center screw of an electrical outlet, ect.).
3. Store all static sensitive chips in the special anti-static foam that they come packed in.
4. Take into consideration several situations that are more prone to static, such as low humidity (dry weather), lightning storms, body friction on synthetic materials

and electric forced fan heaters and clothes dryers.

With a good deal of interest in Spectrum ROM swapping with the Timex/Sinclair 2068, and EPROM packages, "do it yourself" computer servicing is on the rise. Most Spectrum ROM conversion kits come complete with precautionary instructions to use in avoiding static electricity damage, however, this does not necessarily remove the risks.

There is a device that many professional computer service technicians use to get around the problem of static safely. It is called a "static discharge bracelet". The bracelet simply is a metal strip that is strapped around the wrist, with a long wire that is soldered to the band at one end, and attached to ground by means of an alligator clip at the other end. The person wearing the bracelet is securely grounded, rendering any static discharge harmless. You can make your own bracelet at home for a few dollars. All of the parts are easily obtained.

1. Strip of foam-type weatherstripping, 3/4" to 1" wide, and long enough to wrap comfortably around your wrist with an extra inch to spare.
2. 3/4" wide strip of copper foil, approx. the same length as the foam strip without the extra inch. (The copper foil can be found at hobby/craft stores or large plumbing shops.)
3. Two Velcro strips
4. 48" or longer piece of insulated electrical wire.

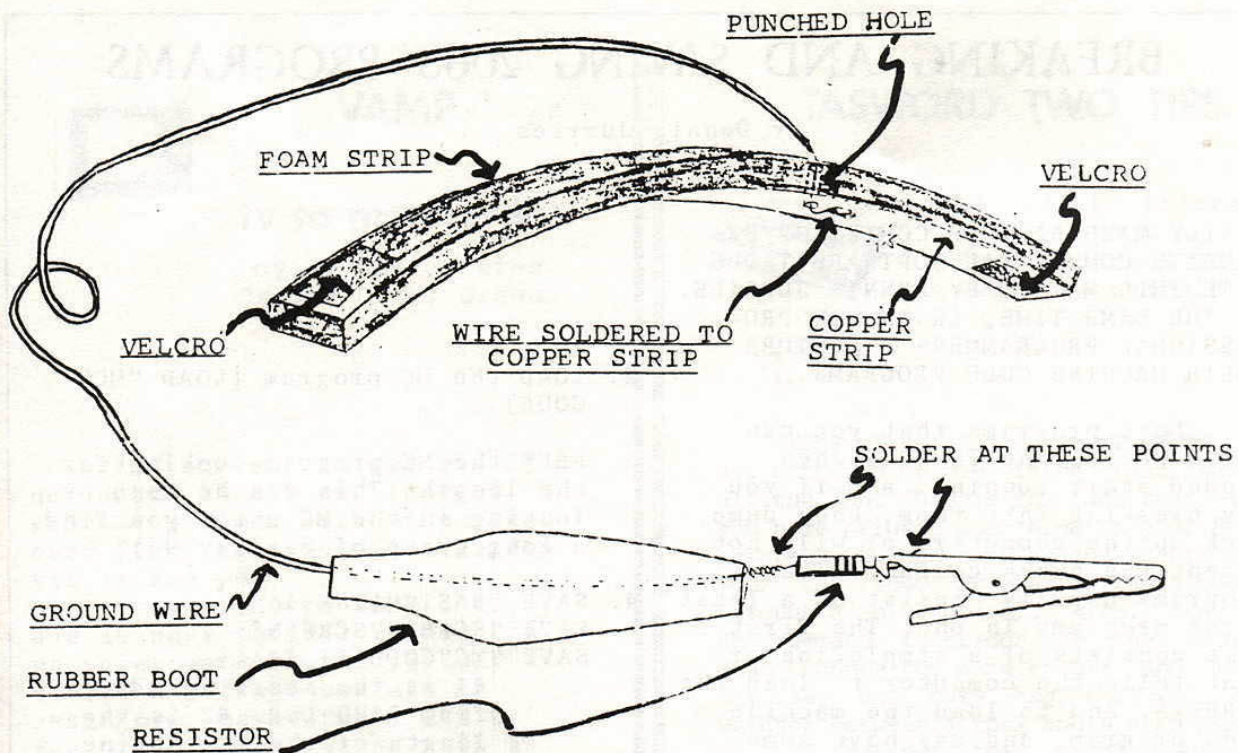

5. One 1/4 watt mega-ohm resistor.
6. One medium-size alligator clip with a rubber boot.
7. A piece of vinyl electrical tape.

Peel off the paper backing of the foam weatherstrip and attach to the copper foil strip. Attach the Velcro strips to each end of the bracelet (either glue or sew a stitch), observe the illustration for proper placement. Punch a small hole thru the foam and copper strips and insert one end of the wire with 1/4" of insulation stripped from the end. Solder the wire to the copper foil, and cover with a small piece of electrical tape, so that the solder joint won't scratch a bare arm (it also acts as a strain relief). On the other end of the wire, strip 1/4" of insulation and slip the boot of the alligator clip over the wire end. Solder the mega-ohm resistor to the wire, followed by soldering on the alligator clip itself. Slip the boot down over the clip, and inspect all the solder connections or places where there might be bare wire showing,

and cover with more electrical tape if necessary.

When using your static discharge bracelet, strap it firmly to your wrist, with the copper foil contacting securely against your skin. Run the long piece of wire to a known ground and attach with the alligator clip. Now you can safely handle computer-related parts and chips as long as your bracelet is properly working for you. Wear your bracelet at all times when you are engaged in such activities...it could save you time and money in the long run.

**Special Note:** Use caution when cutting or handling the thin copper foil strip. The edges are extremely sharp and could cut you. Make sure all sharp edges of the foil are pointing away from your arm, or removed with a file.

# BREAKING AND SAVING 2068 PROGRAMS

By Dennis Jurries

EASILY MAKE BACK UP COPIES OF EXPENSIVE COMMERCIAL SOFTWARE TAPES WITH THIS METHOD BY DENNIS JURRIES. AT THE SAME TIME, LEARN HOW PROFESSIONAL PROGRAMMERS STRUCTURE THEIR MACHINE CODE PROGRAMS.

Most programs that you can purchase for the TS 2068 when loaded start running, and if you try breaking into them, they dump, lock up the computer, or will not accept the break command. These programs usually consist of a least three programs in one. The first part consists of a simple loader that tells the computer to load the SCREEN\$, and to load the machine code program, and may have some BASIC program that intermixes with the machine code program. The first part may be hidden when you break into it by having the BOARDER, PAPER, and INK colors all the same. Change the paper color if this is so, and relist it. You may have to MERGE a line, such as "1 STOP". The MERGE command disengages the auto-start function and thus any command that would normally prevent you from breaking into the program.

The following procedure works in all cases.

MC        -machine code program name.  
BASIC     -basic program name.  
SCREEN    -screen string program name.

1. LOAD the program until the screen display is displayed, then BREAK and LIST. If the program dumps or locks up, then MERGE a line and LIST. This listing will give you the starting address of the machine code (found in the line RAND USR #), the name of the MC, and SCREEN\$ programs.

2. LOAD the MC program (LOAD "MC" CODE).
3. PEEK the MC program looking for the length. This can be done by looking in the MC until you find a long group of 0s (say 96).
4. SAVE "BASIC"LINE 1  
SAVE "SCREEN"SCREEN\$  
SAVE "MC"CODE #1,#2  
#1 is the starting address from RAND USR. #2 is the length of the MC routine, determined by subtracting the starting address from the ending address found when you peeked the MC and found the start of the 0s, or by using the top of memory 65535 (ie. say start address from RAND USR 42000: 65535-42000=23535 then SAVE "MC"CODE 42000, 23535).
5. After completing the above, and VERIFYING each step, except SCREEN\$, press NEW and LOAD the program copy that you have just made, and try it out.

NOTE: You may want to delete any of the statements that would not allow you to break the original program, before you start saving the program. Some of these commands are: ON ERR and POKE 23613,87. DELETE them if you want to.

GOOD LUCK!!!





## VAMP

### tv to monitor kit

by Dennis Jurries  
Oregon City, Oregon

If you want to get rid of un-wanted lines, and improve your TV picture without paying over \$200, then this conversion kit is for you.

I sent \$39 to VAMP Inc., and 10 days later I received a package containing a circuit board, a package containing resistors, capacitors, and a few other parts, along with an eight page instruction manual with schematics. After a couple hours of assembling the PC board and mounting a TV/monitor switch, and the PC board...I was ready to make the circuit/TV connections.

Next, I went out and paid \$8.50 for a Sams Photofact, for my model of TV (Sanyo). The instruction manual tells where, and shows typical examples of where to make the connections. I would still recommend that you either have experience with TV's or know someone who has, and will help you with this part of the project. I made three wrong connections before getting it right.

The final result is a color monitor/TV with a picture every bit as good as that of a dedicated new monitor, for a total of approximately \$48 and a few hours labor.

You can obtain the TV To Monitor Conversion Kit from:  
VAMP Inc., PO Box 411, Los Angeles, CA, 90028.

## TASWORD TWO TIPS



by William D. Erickson  
and  
Paul T. Erickson  
Decatur, Georgia

### 1.

Many of us that use TASWORD TWO are bothered by one thing that spoils all the fun. This is the fact that once you have printed something on your 80 col. printer, you can not again print with your T/S 2040 Printer without going through a big hassel. Also, many of the command functions of the program also produce the same result and leave the user who only has the T/S 2040 Printer between a rock and a hard place.

To correct this problem, go to the main menu by using SYMBOL-SHIFT A, exit to BASIC by pressing b, then add this line to the BASIC portion of the program:

```
29 POKE 26703,0 : POKE 26704,5
```

Now GOTO 25, and save this version of the program by pressing "t".

Now any time your T/S 2040 fails to print, all you have to do is use: SYMBOL-SHIFT A, then press "y" to return to your text and print to your hearts content. This in no way interferes with your 80 col. printer.

### 2.

LARGE PRINT  
USING TASWORD TWO  
and a  
T/S 2040 PRINTER

Set right margin to 32 columns.  
Set window to a 32 col. screen.  
Stay in this mode when you print your text. All other aspects remain the same. Large print still works, just more so.

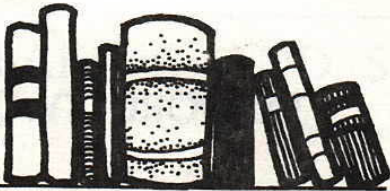

# THE BOOKSHELF

book review by Dick Wagner

Minute Manual For The Dot Matrix Printer  
Author-Jim Pirisino  
Publisher- Minute Ware  
Eight Chapters/164 pages  
Price-\$12.95

The author of MINUTE MANUAL FOR THE DOT MATRIX PRINTER covers the dot matrix printer principles in 118 pages of well written text. His intent is to provide the reader with some knowledge on the subject so a suitable printer can be purchased. Also, he provides a very good background for printer use. Printer features include: print quality, types of print, character sets as graphics and foreign, line spacing and form control. He also goes into printing speed and tests, IBM compatability, noise, and the ability to handle forms.

Very little technical information is given on interfacing. The author does cover the need for interfacing and brings out that this should be considered "part of the computer cost". Some computers come equipped with parallel and/or serial interfacing built in.

Chapters 5 and 6 are probably the meat of the book in that they cover the subject of printer codes, those mysterious numbers and symbols that make the printer recognize computer commands, are discussed in detail. Probably all of the commonly available 80 column printers use ESC as part of the code system. At least the printer manufacturers have agreed on this, if not on the number codes. ESC is generated by a special key on the computer that changes the meaning of a character, so that the printer itself will recognize it as special.

Our 2068 computers do not have the ESC feature, so we are dependent on software to work it out. There are probably knowledgeable people who know how to implant ESC into a 2068 program using LPRINT or COPY to do certain commands such as double-width, ect.

The author uses specific comparisons to show how various makes of printers, even different models, differ in such things as type shape, what they can and cannot do, and the problem of combining printers with computers that don't use the same methods for LPRINT, ect.

The remaining 45 pages are used in covering in detail certain models of Epson, Gemini, NEC, Okidata, Apple and Pro-writer printers. Some comparison is made between certain models of the same make to show differences. The book ends with a comparison chart that the reader can fill out for any printer being considered for purchase.

I was in need of "printer education", after purchasing an Olivetti printer and this book was a great help in deciphering the user manual. This book can help you select a printer and operate it. After all, printers are a specialty, and very little information has surfaced for a person to use in operating a printer.

~~~~~

## RUSSELL ELECTRONICS

### " ROMSWITCH "

Most computer users, except for a select group of "do-it-yourselfers" and experimenters, would be horrified at the thought of opening up their computer and installing a small circuit board. Well the folks at Russell Electronics have almost totally eliminated the fears and risks involved in such an operation, by offering a kit that requires no soldering, no drilling, and no technical expertise. The "Romswitch" is simply a tiny circuit board that is inserted into the socket of the TS 2068 ROM chip that has been removed carefully, then inserted into the empty socket on the Romswitch board. Also, on the board is the Spectrum ROM (type three), and a magnetic reed switch assembly. With the Romswitch in place, the TS 2068 user can utilize almost any software written for the 48k ZX Spectrum.

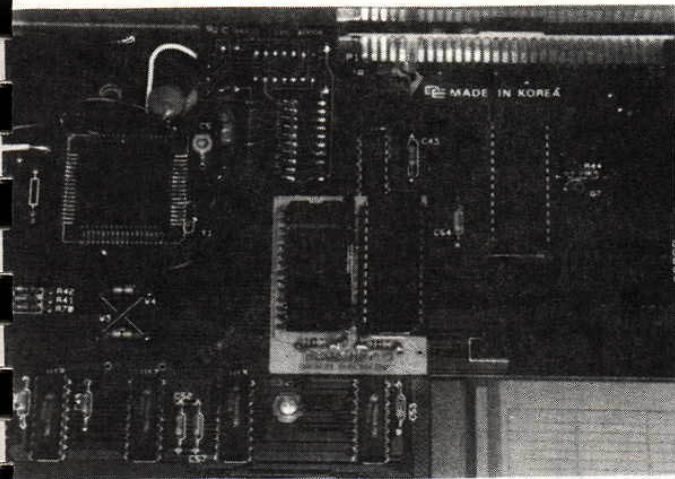

Proper placement of the Romswitch board.  
Note: location is upper left of the cartridge port.

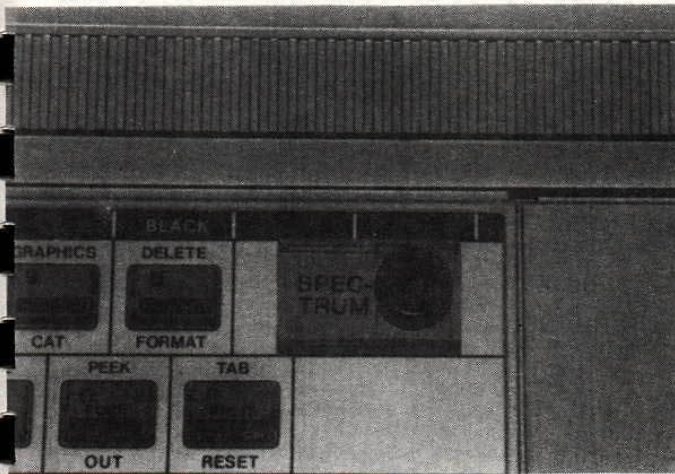

The stick-on magnet switch reads either Spectrum or TS 2068.

The beauty of the Romswitch is the capability of switching between both the TS 2068 and Spectrum ROM operating systems, by sliding the large magnet "switch" assembly that is affixed to the TS 2068s case by means of a pressure sensitive adhesive tape. This is where the Romswitch received its name. Once the blue magnetic slider is positioned properly next to the 0 key and directly above the previously installed board, you are in business.

Russell Electronics has documented each assembly step quite thoroughly in their instruction packet. Almost any question that one might have, has been answered. The completeness of their instructions is a rare "plus", and a feature that is rarely included in most kits that we have seen for TS related products. There are very few risks involved here. The biggest perhaps is static electricity discharge or a broken-off chip pin. Again we recommend following the excellent instructions provided, and use patience and common sense. This will more than guarantee a perfect installation. With our sample Romswitch kit, we installed it in less than fifteen minutes in our TS 2068.

When using the Romswitch, it is necessary to turn the power off when switching from the Timex to the Spectrum ROM (or vice versa), otherwise, the computer will crash. Although this requires an additional step, it really isn't a problem. You will know that you are in the Spectrum mode both because the switch will tell you, and as the computer initializes, only the Sinclair copyright report will appear on the screen. Programming in BASIC is exactly the same in this mode, but some of the keyboard characters have been changed.

We feel that the Russell Electronics Romswitch is a valuable addition to the TS 2068, and extraordinarily easy to install. Although at first we thought that the price of \$54.95 (includes postage) was somewhat high, after obtaining some excellent Spectrum programs and using them on our Timex, we began to reconsider our first impressions. The Romswitch is a big improvement over direct replacement of a Spectrum ROM in a TS 2068, and so far to date, has run every program that we have loaded, and has never failed. We recommend the Romswitch without reservation. Good work Russell Electronics!

For more information: Russell Electronics, RD 1, Box 539, Centre Hall, PA, 16828

# THE Z-LINK INTERFACE ..... a synopsis

by Dave Clifford

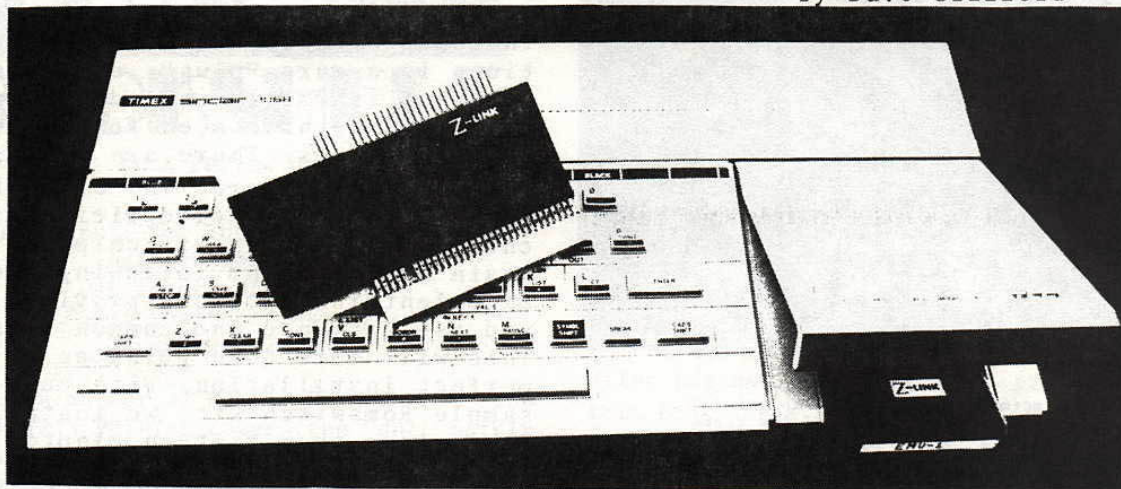

Simply put, the Z-Link Interface Card is a "plug-on" device that re-configures the peripheral I/O port connector pin-calls of the Timex/Sinclair 2068, to match that of the Sinclair ZX Spectrum Microcomputer, and thus making the TS 2068 "HARDWARE COMPATIBLE" with Spectrum peripherals.

The Z-Link makes available to the peripheral, all required address and data lines, as well as "hand-shaking" and "house-keeping" control lines required by the Z-80 CPU. The Z-Link also supplies the two additional supply voltages (+12v and +9v), via two type LM-78 series 3 terminal regulators.

The regulators are filtered with temperature-stable tantallum capacitors to guard against noise and "self-oscillation" (an inherent problem that is "overlooked" by many commercial designers), until the system is switched-on. As with all digital systems, the secret to successful circuit operation is good connections, a common ground return, liberal distribution of by-pass capacitors, and a "quiet" power supply!

That describes the Z-Link Interface Card. NOW, you are wondering what it's uses are. I could say that it will "RUN ANYTHING" (but that would be both un-fair and inaccurate in my book). I will however describe the systems and peripherals that I HAVE and DO USE...AND USE EVERY DAY!

But first, I want to say something about "EMULATORS", and clear the air about these devices. Without getting too deep into the subject itself (it would take the entire magazine), it is here that I will say that YOU NEED ONE to use Z-Link...but which one?

There are two basic "types", the first is known as "The Spec-

trum Emulator" or EMU-1, brought to life by Doug Dewey (The Triangle T/S Users Group), and consists of a 128k EPROM that is mounted on a p.c. card that is fitted into the TS 2068's Command Cartridge Port. The second is known by the trade name: "The ROM-SWITCH" (editor note-see review in Jan/Feb 85 issue of T.D.M.). This one consists of an actual Spectrum ROM, mounted on a p.c. card with a second socket for placing the TS 2068's "home ROM", then the entire assembly is fitted inside the 2068 (plugged into the "home ROM" socket).

The DIFFERENCE between the two is the ROMSWITCH is manually switched-in, and becomes the 2068's sole "operating system"...some control keys and built-in hardware become "transparent", because the Spectrum ROM does not contain the "instructions" for their support (i.e. SOUND, FREE, STICK, and the cartridge port).

The type EMU-1 and EMU-2 however "sits" in the cartridge port and is "BOOTED" into play by the 2068's home-ROM. But what really makes the difference is that the 2068's "SHADOW-ROM" is brought on-line as well. It is this SHADOW-ROM that contains the instructions, that enables the TS 2068 to "commucicate" with the "smart" peripherals like the Interface-1 and Microdrives, or the Rotronics Wafadrives, with the "help" of the EMU-1 acting as an "interpreter"...and thus "EMULATES a Spectrum".

And now the peripherals!!!  
With space being at a premium, I will discuss the operation of two of the "most popular" systems that seem to have the majority of users "baffled", the ZX-Microdrives and the Rotronics Wafadrives.

I have had the Sinclair ZX Interface-1 and two ZX Microdrives

# THE OMNI-EMU

by Tim Woods

ON-LINE since October '84, and have used the system extensively. I do all of my word processing with Tasword-II installed on Microdrive Cartridges, and have just installed Masterfile... (FANTASTIC!). But the drives themselves are only PART of the system. The Sinclair Interface-1 also has an RS-232 interface, as well as a unique L.A.N. (Local Area Network) for "networking" up to 64 Spectrums (or 2068's), that are also fitted with the Interface-1. (There are five users here, in the South Bay TS User's Group that are presently running the Interface-1 and Microdrives, and sometime when we can all get together, I would like to try a game of HUNTER-KILLER on the L.A.N.)

The second system that I have just received from the United Kingdom, is the Wafadrives. This is a "twin" drive system custom manufactured by BSR (the well-known audio people) for a company called ROTRONICS. I have had this system on-line for the past two weeks and it is a VERY user-friendly system. When brought "on-line" it sports it's own operating system, and has commands VERY similar to CP/M. In fact, Rotronics refers to the operating system as "W.O.S." (as opposed to CP/M's DOS). On top of having two 128k drives, the Rotronics Wafadrive also has an RS-232 AND a Centronics Interface BUILT-IN!!! I even use the Westridge 2050 Modem with the Wafadrives! (Yes, the 2050 Modem is plug-compatible with the Sinclair Spectrum. Even MTERM II runs on the Spectrum. However, when you go back to BASIC, you will crash. This is due to MTERM's call for BASIC. Machine Code hackers... get out your "HOT-Z" or "DISA-Z" and go to work!)

The above systems are operated with the Z-Link Interface and the EMU-1 (or EMU-2), as supplied by Doug Dewey.

WHAT'S NEXT??? I am WAITING for one of two interfaces from the U.K., that support STANDARD 5¼ floppies. Gaze through a copy of ZX COMPUTING sometime and let your imagination "FLY". (The prices will amaze you too!) I just wish that Mother England had and equivalent to U.P.S. Blue Label... (at the same time, I'm glad she does not!)

The Z-Link is priced at \$49.95 and is available from: TEJ COMPUTER PRODUCTS, 859 North Virgil Ave., Los Angeles, CA, 90029.

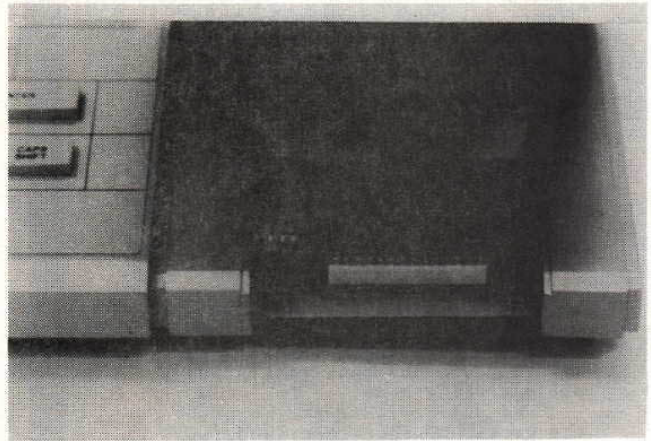

The OMNI-EMU is the very latest version of Spectrum Emulator or "Chameleon" designed by Doug Dewey (Triangle Sinclair Users Group). It is sold through Doug's company "Enter Lengua", and now by several different Timex/Sinclair vendors. The OMNI-EMU replaces the previous EMU-1 (the EMU-2 is still available). What is the difference? First of all a 27128 Hitachi EPROM, that is presently the only means of operating the Sinclair Microdrives and the Rotronic's Wafadrive is a new feature. The Emulator board itself has been designed to be very versatile... a DIPswitch (mounted on the board) can access the four 16K blocks of memory for specific application purposes. The supplied EPROM can be swapped with other LROS (language ROM Oriented Software), the board can act as a cartridge (AROS) or a ROM board. Some jumpers may be required depending upon the particular use. Actually the documentation for these advanced applications of the OMNI board are still currently being written.

The OMNI-EMU as supplied, will allow the T/S 2068 user to run "almost" every piece of software available for the English 48K ZX Spectrum. It had been originally thought that the "chameleon" device would not run as many titles as a direct issue 3 Spectrum ROM replacement of the 2068's "home ROM". This however, is not really true. In fact some software said to be un-loadable will run on the emulator. There are still a couple titles that won't load or run, like "Chequered Flag (PSION), Toolkit (Hi Soft), Valhalla, and few others. The Reason? "Interrupt-driven" programming techniques appear to be the culprit, and the common source of problems here.



The OMNI-EMU, like it's predecessor the EMU-1, slips into the Command Cartridge port on the TS 2068. Our sample fit very securely with no insertion problems. The door to the cartridge port is able to close, with the Emulator tucked safely inside. At a first glance the OMNI appears to be a very quality board...compact, gold plated edge-connector fingers and plated through holes. I understand that each new Emulator is thoroughly tested before it is shipped. Plus there is a two year warranty! The only problem that we foresee, is possible mishandling by the user. Be extremely careful when handling the bare board, that the foil traces and semi-conductors aren't touched (static discharge). Always make sure the power is off when you insert the board, and also when it is removed...when you want to return your 2068 back to its normal operating mode.

We put our OMNI-EMU through the paces, by test-loading 12 of our Spectrum programs. All 12 were a successful load! Absolutely no problems. When the OMNI is first switched on, it is interesting to point out that the 2068 first switches to it's normal mode for an instant, then checks to see what is in the cartridge port... when the Spectrum mode is initiated (Sinclair copyright notice alone).

We strongly feel that the OMNI-EMU is a good way to go for Spectrum conversion. First of all, the user will not have to tamper with their computer (as is the case with "Romswitch" or direct Sinclair ROM replacement). Secondly, this is the only method of "booting" Sinclair Microdrives or Rotronics Wafadrives. Then coupled with the new price of \$50.00, it is an excellent choice that should be considered.

# SPECTRUM SOFTWARE

## WHITE LIGHTNING

by Michael Carver

"White Lightning is a high level graphics development system for the Spectrum 48k." (This program can be used with the TS 2068, with Russell's ROMSWITCH or other Spectrum ROM add-ons.)

You want to create some exciting arcade game, but have realized the limitations of speed in BASIC, or have encountered the need for a mastery of machine code you know is still months away. Maybe you have a short movie running through your head that you would like to produce. Then White Lightning is for you.

White lightning comes in a library case with two cassettes (4 separate programs), one manual (131 pages), and a "cheat sheet" which contains a sample Lunar Lander game, and useful subroutines. Two of the programs are demonstrations of the possibilities using White Lightning. One is about 20 minutes of 16 different animated programs. The other displays 167 arcade sprites included with the software; (i.e. Asteroids, Pac-Man, Defender, Frogger, Donkey Kong, and many more). The other cassette contains the Sprite Development Package and White Lightning proper.

### SPRITE DEVELOPMENT PACKAGE

A sprite is a defined picture or graphic element which is stored in memory to be called up and put onto the screen when needed. The sprite is placed whole on the screen, not plotted or drawn. Some computers limit the size or amount of sprites that can be developed. The Commodore 64 allows only eight sprites per program. The TI/99 allows 32 sprites, but they can only be 8 pixels by 8. With White Lightning, one can have 255 sprites of any size (within

memory limitations). They can even be larger than the screen.

Sprites are generated using the Sprite Development Package (SDP) by defining each 8x8 pixels grid to be incorporated into the sprite. One plots out each pixel to be set, paper and ink colors and other attribute assignments (see fig. 1). These grids are then pieced together like tile on the larger screen to the right, making up the sprite. The completed sprite is then given a number and stored in memory. Within the SDP, the largest sprite possible is 15x15 characters, but these can be joined later in White Lightning to create large sprites.

SPRITE 1

SPRITE 2

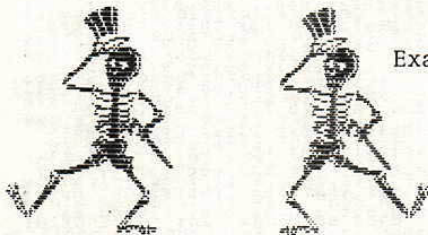

Example 1

To make the skeleton move right one step, the following FORTH definition is used:

```
: STEP 1 COL +! 2 SPN ! PUTBLS 1
SPN ! PUTBLS ;
```

In English: Sprite 1 is on the screen and Sprite 2 is placed on the screen 1 column to the left and over Sprite 1. Sprite 2 is then placed on the screen directly over Sprite 1.





From the fantasy worlds of Tolkien and C.S. Lewis, comes a similar "epic" adventure in the form of a Spectrum game program called "The Lords Of Midnight". The story background is typical...the struggles between good and evil. In this case, Luxor the Moonprince and his son Morkin battle the realm of Doonark and the ice-fear. There are actually two separate ways to play the game.

The most fascinating aspect of "The Lords Of Midnight", is the elaborate graphics system. There are 32,000 scenes in all! The players ability to spot certain landmarks on the horizon, will help in deciding the outcome. The graphics are very nicely done. With horses, wolves, armies, and an intricately detailed landscape...the programmers deserve a good deal of praise. Most of the scenes have small parts of other scenes to construct what is on the screen. By operating the keyboard, you actually "move" forward through the "Land Of Midnight", and the scenery in the distance appears to get closer (any number of directions can be chosen).

Another nice attraction of this program is the packaging. It is supplied with a "library-style" case, a very comprehensive 29 page manual, and a plastic keyboard overlay. I thought I would take this time, to point out to you novice Spectrum fans, that all keyboard overlays designed for the ZX Spectrum, also fit the Timex/Sinclair 2068 perfectly.

## THE LORDS OF MIDNIGHT

by Tim Woods

Getting back to the users manual, it is very explanatory and detailed (actually it is more like a small paperback book), and even includes a background story with five chapters called the "Midnight Chronicles".

Some other features worthy of mention include: the facilities to SAVE a game in progress to tape, and each graphics scene can be sent to the printer (including the 2040), to give you a running account of your quest.

"The Lords Of Midnight" is a very playable game, and even somewhat habit forming. It is slightly different than an "all-text" adventure game. In fact the text itself is very sparse. No standard adventure commands or jargon is needed, since most of the games control commands are one-button functions (featured in a few on-screen menus) on the keyboard. If you do not have a copy of this game program, and it sounds in the least bit interesting to you...I would suggest that you go out and obtain one. "The Lords Of Midnight" is hard to beat by any standard.

It also might be interesting to point out that this adventure game is actually part of a trilogy. Part two of the trilogy is already out on the market, and it is called "Doonark's Revenge", and is reported to have 48,000 entirely new scenes. Later this year, part three which is entitled "Eye Of The Moon", will be released.

Our copy of "The Lords Of Midnight" was obtained from: E. McGhee, Suite 150, 10127-121 Street, Edmonton, Alberta, Canada, T5N 3X1.

\*\*\*\*\*  
 Special Offer For Readers Of Time Designs Magazine: E. McGhee is offering "The Lords Of Midnight" at a special price of \$23.50 for you. The price includes shipping and handling. Also, an issue 3 Spectrum ROM chip (plus chip puller tool and detailed instructions for the TS 2068 are included) for \$19.50. Send check or MO, in U.S. dollars to address above.  
 \*\*\*\*\*





## BRAXX BLUFF

by Tom Judd

Do you like an arcade game that is both very easy to play, and extremely challenging? Then I have the program for you...it is called "Braxx Bluff". That is kind of a strange name for a game, it is called that because you have to rescue some stranded space travelers from a place on the planet Prolon called "Braxx Bluff". Like I said earlier, this game is easy to play. It uses only the cursor arrow buttons, and the "0" for the FIRE button. It would be nice to have a joystick to play, and there are provisions for a British joystick interface, but unfortunately, I do not own one.

Even though the controls are simple (this is refreshing compared to other games that require you to press a lot of buttons at once, and remember a bunch of details), the game provides you with continuous entertainment...with variety. This is a multi-screen 3D rescue game.

The first part, is a very neat landing sequence, when you approach the planet in your spaceship. The graphics here are fantastic! This is a tricky part, but once mastered, you will be on the planets surface (on foot) in search of the survivors and the wreckage of their ship.

To help you with your search, you will also need to find a "land-crawler" vehicle and later a "sea-crawler". At the same time, you need to be on the look-out for the space "beasties" that can kill you, if you don't shoot them with your laser gun.

Well, I haven't made it very far, but that is what keeps me going. You can SAVE your present position on tape, for play at some other time. If you blow it, you have to start all over from the beginning.

"Braxx Bluff" was a pleasant surprise to play. Very good graphics, excellent sound effects, and an extremely addictive game. (I obtained my copy from Software Supermarket, England.)

## SPECTRUM SOFTWARE

reviewed by Michael E. Carver



### WELCOME TO THE MACHINE!

DEUS EX MACHINA (Latin) noun, (1) Power, event that happens at the right moment to solve difficulty. (2) A god, introduced into a play to resolve the plot.

When I first saw the ad for the Spectrum program "Deus Ex Machina", my interest was piqued. They offered a "televised fantasy" which was synchronized to a stereo soundtrack, starring yourself, plus Ian Dury, Jon Pertwee, Mel Croucher, Donna Bailey and Frankie Howerd.

For those of you who are not Anglophiles, Jon Pertwee was one of the various Dr. Who's in Britain's long-running sci-fi television series of the same name. Ian Dury is a long-standing rock musician with a "bent" sense of humor. Frankie Howerd is a comedian who has worked in film with Peter Sellers, and in television.

Let me assure you, it did indeed live up to my expectations! The animation is detailed and smooth. The soundtrack stands on its own as a work of art. Machina is a novel and refreshing approach in computer programming. Not only is the concept of a soundtrack with storyline new, but the ideas embodied in the game itself are of a different nature than the usual shoot-em-up games. You are asked to touch, caress and nurture a new life into existence, guiding it through the seven ages of development, from conception through old age.

The year is 1994 and the Central Computerized Data Bank which holds all the Police and State Security records of the United Kingdom becomes all powerful. Then ..."Tuesday evening, after tea and compulsory prayers, the machine rebelled..." You, the player, are invited to control the machine's development of a new life while helping it avoid the dreaded Defect Police. The instructions are rather cryptic, but then so are the lessons we receive during life. It will take many plays just to learn exactly what must be done and many more to achieve any great expertise.

It would appear that this program was developed using FORTH and an animation package similar to "White Lightning" (see T.D.M. issue #3). The soundtrack is a professionally produced "opera". Just listening to it is reminiscent of the power and novelty of the musical "hair" or of Pink Floyd's, the "Wall", and of National Public Radio's broadcast of the "Hitchhiker's Guide To The Galaxy."

Deus Ex Machina is not a child's computer game, but a mature science-fiction fantasy-morality play-interactive adventure. The program is controlled by the keyboard (4 keys--up, down, left, right), or by Kempston or Interface 2 joysticks. The program was written by Andrew Staff and Mel Croucher and published by Automata. My thanks to all of those who worked to make this program a reality. I hope to see more great ones in the future. I hesitate to say more, and thus destroy the sense of discovery or even ruin the plot.

Machina comes in a book-sized storage case with two cassettes (one for the computer and one for the soundtrack), a poster and a complete script. The program was obtained from Speedysoft (formerly Software Supermarket) 87 Howard's Lane, London England, SW15 6NU for £15.00 plus £1.50 for postage. They also have a 24-hour telephone order number: 01-789-8546.

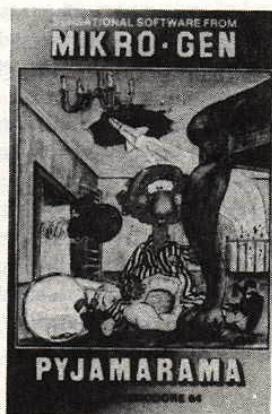

## ASLEEP AT THE WHEEL

Your name is Wally Week, you are asleep, and you are having a nightmare! This is no normal nightmare. If you cannot find your alarm clock and wind it up you will not wake up and will be late for your work. If you are late, you lose your job. Welcome to "Pyjamarama", an arcade game for the Spectrum from Mikro-Gen.

This is an excellent and cute game. Wally's alter ego must persevere through this nightmare and find some way to wake the real Wally up. (Note: Wally is Cockney slang for a cucumber cured in brine--a "pickle-brain".) In order to wake Wally up, a series of tasks must be performed and in a dream this may be no easy chore. You control the character via the keyboard (you can define your own keys--only 3 are needed; left, right, jump) or with the Kempston or Interface 2 joysticks. You must explore the numerous rooms of Wally's nightmare house and collect objects to help you obtain your goal. In the process of collecting these objects, you must dodge devouring roasted chickens, ghosts, flying axes, grasping hands and many more surreal foes. Wally can only carry two objects at a time. Sometimes one or two items are needed to pick up a certain object. you have three lives, but as you progress through the house you lose snooze energy or some of the nightmare goblins will snatch it away from you. No snooze energy and your life is gone. Keep your eyes open for midnight snacks to bring your energy back up.

This is a very amusing graphic arcade game. The character is easy to control and there are large colorful graphics. Each room is richly drawn with chairs, boxes, barrels, and tables to climb on. The animation is smooth and quick. The only complaint I have about the graphics is that some have color attributes which "bleed" onto the background, but then this is a dream! Strange things happen to Wally, like entering a video arcade game of invaders. Wally becomes a part of the game and must fight the invaders (houseplants, roasted chickens, ect.) which drop bottles and telephones and other household appliances onto him while he fights back with shooting forks.

You may find logic a drawback while trying to figure out parts of this game, remember this is a dream. It will take you many plays just discovering the various rooms and the means to enter them. Many more will be spent finding the order in which to obtain numerous objects. Even after you have figured out the pattern of the game and have woken Wally up, you can still play with the added challenge of trying to win with the least amount of steps.

If you like your arcade games with a good laugh, Pyjamarama is for you. The cassette comes packaged in a regular case with full instructions and even a little story. My copy was obtained from Speedysoft for the ridiculous price of £6.95 plus £1.50 for s & h.

#### THROUGH THE MAGNIFYING GLASS

You have inserted the cassette into your player and the computer has dutifully loaded the program. You now find yourself in Victorian England, sharing a flat with a doctor, overlooking Baker Street. Yes, you deduced it, you are the famous detective, Sherlock Holmes. This is the setting of the new Spectrum adventure program from Philip Mitchell and Melbourne House, the people who gave the computer world "The Hobbit".

Again we have a text adventure with graphics, featuring "Animication" of characters, "Animtalk" and "Inglish". What does all that mean? Well, Animication is the independent actions and movements of all the characters in the adventure. They will follow courses of action based on their personality and the situation they find themselves in. Animtalk is the ability for you to speak to any character in the adventure, asking them questions or telling them to do a particular task and for them to talk back. You will find that at times, the characters do not cooperate, due to Animication. Inglish is the easy way in which you communicate with the computer and the adventure (i.e. "Open the ornate door and go through the door.") Also included, is a "real-time" feature. Time passes as Sherlock examines items, questions witnesses, or rides on the rail-

car. This is a very rare element of test adventures and an added challenge. You can also save your progress to tape and reload it back into the computer. This will allow different approaches to be tried and prevents having to start over if you allow Sherlock to be killed.

As Sherlock Holmes, you find yourself confronted with a mystery as yet not chronicled by Watson. (Note: you can use your printer as a chronicler of your adventure by using a print feature which will print out all actions and graphics if you so desire, see example.) This is a mystery which has completely baffled the local police and you can bet that Inspector Lestrade will make the wrong conclusions. You must hunt down the clues, make your brilliant deductions and find the real criminal. The computer has a vocabulary of over 800 words and can carry out over 53 different actions.

You are in a large lavishly decorated bedroom, a broad window overlooks a small lane leading north. Below there is the staircase. To the east there is the window, you can see basils bed, basils piano, a gramophone and the window. Watson enters.



I have found this adventure very challenging and well worth the purchase price. I have spent many hours, which have turned into days, which have turned into weeks...and I have yet to solve the final mystery. Sometimes the deductions come easy, but obtaining evidence can be quite the task. I have a few qualms with the program. I have found no means of using all of the vocabulary listed in the accompanying manual and a few glitches have shown themselves, none with major consequences. The most annoying is an "out of memory" report from the adventure itself. One must then reload a saved portion of the game in order to continue. Still, I must highly recommend this program to any mystery and/or adventure lovers in the audience. After all, a program of this size and scope is bound to have a few bugs in it.

Sherlock comes in a small book-sized box, with an instruction manual, and a train schedule. Available from Speedysoft for £14.95 plus £1.50 for postage.

SOFTAID  
Feed The World



There is a cassette tape available featuring ten top hit game programs from England, for the Spectrum computer. All proceeds from the sale of the software go to the BAND-AID TRUST FUND to aid starving Ethiopians. The Band-Aid project was first implemented when British Pop Music Stars recorded and donated a Christmas song for

the effort. The "greatest hits" tape is called SOFTAID, and contains the following games: Spellbound (Beyond), Starbike (The Edge), Kokotoni Wilf (Elite), The Pyramid (Fantasy), Horace Goes Ski-ing (Melbourne House/Psion), Gilligan's Gold (Ocean), Ant Attack (Quicksilva), 3D Tank Duel (Real-Time), Sorcery (Virgin), and Jack and the Beanstalk (Thor). On the "flip" side of the tape is the recorded version of the song "Do They Know It's Christmas?"

Rod Cousens of Quicksilva organised the software relief project, and hopes that it will raise some £200,000 for the Ethiopians. Here in the U.S. the SOFTAID Spectrum tape is available from Susan Ziegler, Software Services, 14307 BenBrush, San Antonio, TX 78248, for a mere \$6.25 plus \$2.00 for first class p & h. Bob Dyl of the English Micro Connection, 15 kilburn Ct., Newport, RI 02840 will also have substantial supplies of SOFTAID shortly. The British software producers have been very generous in their efforts. The tape is very reasonably priced, and everyone should obtain their own copy...pirated versions won't help dying people one bit. Note: There is also a version for the Commodore 64.



## AMERICAN FOOTBALL

reviewed by Tim Woods

I obtained this program because it sounded like a good "warm-up" for a certain interest (or "habit" as some may like to call it) that I have in the Fall. You may have guessed by now, that it is Pro Football, but I will not bore you with details about my favorite team (except that they are from the northwest, wear blue jerseys, and made it to the play-offs last year!).

AMERICAN FOOTBALL is a Spectrum program on cassette that is published by the Argus Press Software Group (ZX Computing). What makes this program sort of unique, is that the British are just now starting to appreciate our brand of "football". They even have organized minor league teams to root for. I remember watching a TV news interview with some English youth that were playing the game of football (non-soccer version) in a neighborhood lot. The broadcaster asked, "How do you like the game?" One very muddly-appearing young man

spoke up, "We love it...but we don't understand it!" Indeed, the program American Football comes with a 16 page guide entitled "A Guide To Understanding American Football". The wording is sometimes a bit odd.

The game of American Football itself, is similar to a program that used to be on the Timex label for the T/S 1000 called "Strategy Football". This version is much more sophisticated. To "play", you must choose from a menu what offensive or defensive move you would like to make. The key to winning, is to try and "outguess" what play your opponent will try and go for. Your opponent can either be a friend or the computer itself.

The action on the screen is simulated by tiny pixel-ated players. One of the problems with this game, is that the opposing teams don't "huddle" facing each other, but rather on the sides of the field.

A lot of work has gone into making this game authentic. It is played from the view of a team coach (or like one of those guys that sit up in the box seats with headphones on). With a set number of plays to choose, the game becomes predictable after awhile. I think that I would opt for a type of computer football game that is in 3-D like the "MATCH POINT" soccer game.

Over-all, AMERICAN FOOTBALL is an interesting package with nice screen displays and a lot of little extras...and at a good price too!

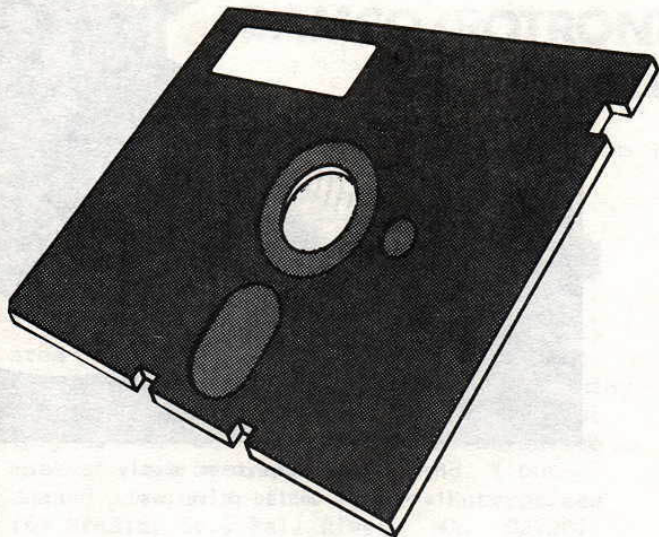

## AERCO FD-68 DISC DRIVE SYSTEM FOR THE 2068 PART 1

reviewed by Dennis Jurries

A week ago, I had the honor of receiving number 20 of 20 pre-released models of the FD-68 Disc Drive System for the Timex/Sinclair 2068 from Aerco, for review. After a bad experience with trying to obtain the Millennia K Disk Drive Interface from Ramex (see accompanying article), I was leary of looking at an incomplete disc operating system (DOS), but I was pleasantly surprised. (Editor's Note: Aerco will be releasing updates for the interface board as improvements are made. Simply replacing the socketed EPROM is all it takes. Aerco will provide the updates free. In fact, right after our review unit was shipped, we received the first EPROM update. Eventually, the FD-68 will contain all of the extensions, and a proposed Spectrum mode.) The main commands to operate the system are:

```

FORMAT "", ..... to format disc
MOVE "n.X", ..... to save to disc
CAT "n.X", ..... to load
ERASE "n.X", .... to erase program
                  from disc
CAT "", ..... to call disc
                  catalog menu
  
```

n = name of program (1 to 10)  
x = extension as follows:

```

.ARO - refers to dock bank
.BAS - basic program
.BIN - binary data (machine code program)
  
```

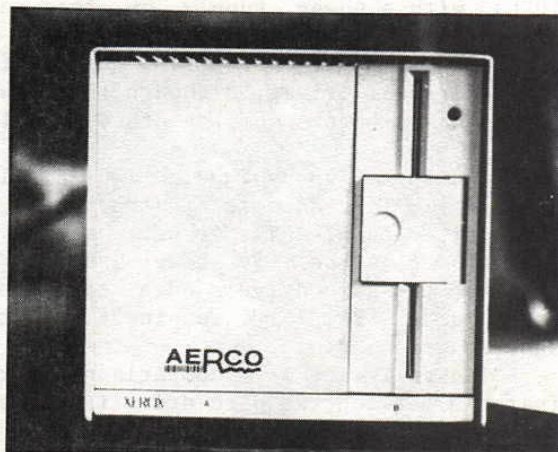

Aerco single 2/3 ht. floppy drive  
in cream colored steel case.

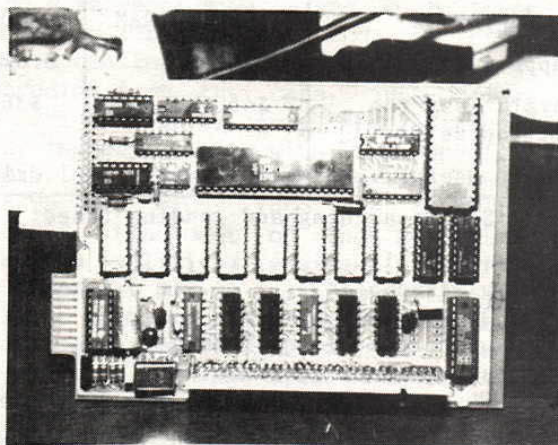

Fully populated interface board was designed using Apple's MacPaint. Note: DOS EPROM is shown in upper right-hand corner

```

.BUT - boot program to be executed at
       start up
.CHR - character array
.DAT - numeric array
.LRO - LROS runs in dock bank starting
       at 0
.SCR - screen is a copy of the video
       display
  
```

```

Examples: CAT "tasword.BAS",
          MOVE "zeus.BAS",10
          MOVE "zeus.BIN",#,#

```

# = start and length of MC

The system comes with an interface that is 4 inches tall by 6 inches long with through edge connector for other add-ons. There is also a boot disc and a 2/3 height Remex drive in a case (6 5/8" X 7"W 10"L), with a power supply on the end, extending the length to 13 inches. It appears that there is room in the case for two additional drives, although the power supply and ribbon connector are set up for two maximum.

I also set up my Tandon 100-2A disc drive following Aerco's instructions in their literature. A jumper wire had to be installed from the +5v power supply to pin 2 of the disc drive's edge connector, and a jumper from +12v to pin 34 of the same edge connector.

The following is a comparison of the features between two disc drive interfaces available for the T/S 2068:

|                             | RAMEX        | AERCO   |
|-----------------------------|--------------|---------|
| 1st drive                   | QUAD density | any     |
| memory used                 | 4 to 8k RAM  | ROM     |
| approx. speed               | 32k/sec      | 8.6k/s  |
| syst. cost (do it yourself) | \$450        | \$380   |
| to be useful...             | 2 drives     | 1 drive |

Some searching and loading times:

```

Tasword II ..... 5.7 sec.
Zeus Assembler ..... 3.5 sec.
A 37.6k BASIC program
I wrote that loads from
cassette tape in 3 min.
& 14 sec. .... 4.87 sec.

```

On a double-density, double-sided disc, you have 400k of memory storage. I believe that with the 64k additional RAM in 8k bank switching, the RGB output port, and the DOS on ROM, make this system the best buy for your money. In the next issue of TIME DESIGNS, I will give further information on the Aerco Disc Drive I/F.

System available from: AERCO, Box 18093, Austin, TX 78760. Cost: Interface-\$199, Drives- \$99 each, Power Supply/Case-\$99. CP/M Boot Disc will be available soon for the FD-68 (Kaypro/Osborne version).

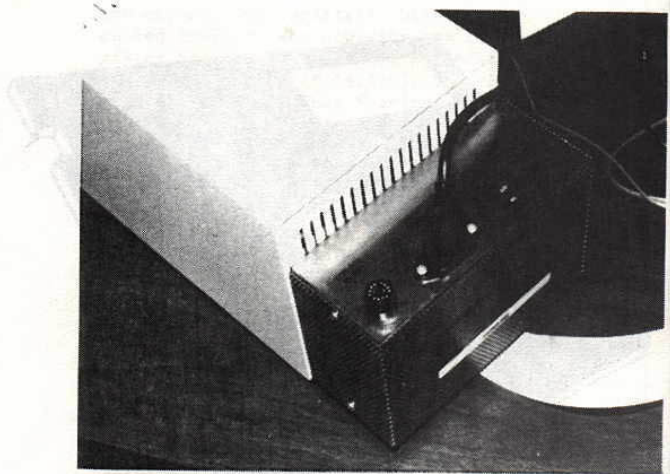

Heavy duty 5 amp power supply is mounted behind drive case.

## REPAIR DATA

If your disk drive is exhibiting LOAD/SAVE problems, there may be two possible solutions. 1. If you can transfer a program onto a disk programmed on your drive, but cannot a program from another unit (like a commercial disk), the head is out of alignment. You will need to have a technician repair it. 2. If you can neither SAVE/LOAD programs from your unit, the problem may be in the head load button pad. This pad gets dirty and/or worn, and can cause problems. It can be removed and replaced easily by the user. Replacement button pads can be found at part houses.

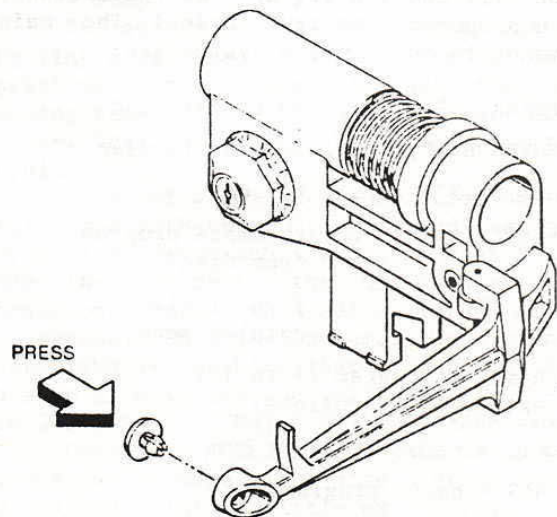

# THE DAMCO/ROTRONICS WAFADRIVE REVIEWED

by Tim Woods

If you have a very limited work area dedicated to your 2068 computer, or have a small home business, the following product may be of particular interest to you. It is the Rotronics Wafadrive mass-storage system from England. I purchased our unit from Damco Enterprises (67 Bradley Ct., Fall River, MA, 02720), who is the exclusive distributor of the Wafadrive here in the U.S. Damco has put together a special package that allows the Rotronics Wafadrive to operate on the T/S 2068, since the system was originally designed for the Sinclair ZX Spectrum. This package includes all of the "goodies" that come with the stock Wafadrive (which we will discuss shortly) plus a cartridge-style Spectrum emulator, and an adapter for the 2068's expansion port. The Spectrum and the Timex have different rear-edge ports.

When the Rotronics Wafadrive arrived in the mail, I was first struck by the size of the box it came in. Very small, to say the least. And the unit itself is quite compact. It reminds me of a Tupperware container with a lid (only black). The old saying, "good things come in little packages," seems to fit here. The Rotronics has not just one drive, but two. They are the "stringy floppy" type, which use special micro-cartridges (or wafers) designed by Entrepo. The Wafadrives are custom manufactured by BSR (the audio company) for Rotronics. Just for your information, A & J Microdrive uses the exact same wafers in their system for the 2068, but the similarity stops there.

Along with the dual drives, there is also a built in Centronics parallel printer interface and a R232 serial interface. The ports for these interfaces are at the rear of the unit along with a normal Spectrum expansion port, to which a Timex 2040 or ZX Printer can be attached. On the front of the Rotronics

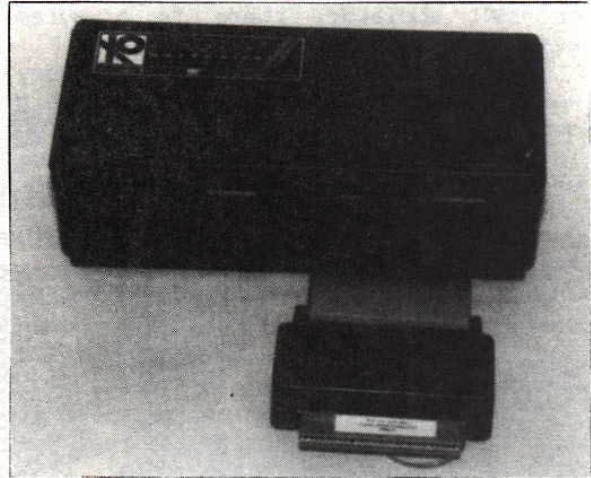

are the two Wafadrive slots (drives A and B respectively), along with three LED's: one for power on, and the other two designating which drive is active. Protruding from the case, just below the drives, is a very short (about four inches) cable with the special adapter already connected to the end. This is what plugs into the rear of the 2068. Placement of the Rotronics Wafadrive is limited to directly behind the computer. For my installation, it posed a slight problem, but shortly corrected by moving the monitor off to one side.

Also in the same little box came two wafers. One is blank, and the other is a free word processor program from Softek, which is customized to work with the Rotronics. It is supplied with a 40 page manual, and is fairly comprehensive (ie. 64 col., auto word wrap/justification, page numbering, screen editor, block operations, ect.). This is a nice touch, to include a program that can be used right away with the system.

A 68 page manual is provided for the Wafadrive. The manual is spiral bound, and is clearly written and suprisingly detailed...giving some examples as it covers each concept.

You may be wondering what a system like this costs. Especially with all of the extras that are included. It is only \$229.95 from Damco, plus \$5.00 for postage. I also ordered the optional Centronics cable for \$12.95. If you are the owner of a Spectrum, there is a version of the Wafadrive for \$169.95. For those of you who already have an EMU-1 or OMNI emulator, there is a system available for \$199.95.

How does it all stack up? Very well indeed. The Wafadrives have their own operating system (WOS) in ROM, which is similar to disk operating systems used by other computers. Extended BASIC commands are used and typed in from keywords on the 2068 that were originally reserved for use with the Sinclair Micro-drives. These are CAT, FORMAT, OPEN, CLOSED, ect., along with standard commands like LOAD, SAVE, MERGE, and VERIFY. The symbols "#" and "\*" are also used.

The following is an example of a command that is used to ready a blank wafer for transferring data:

```
FORMAT*"a:wafername"
```

"a" is used to denote which drive is being activated.

Loading time was fast. Transfer baud rate is rated at 18k. I timed the supplied word processor program, and it loaded in 30 seconds. A comparable cassette program would take three minutes or longer.



Wafers are available in three sizes (or storage capacities): 16k, 64k, 128k. They appear to be rugged for their tiny size, and have a plastic sliding dust cover. A wafer has a continuous loop of magnetic tape inside, and operates on a principle much like the old eight-track audio tapes. The shorter tapes will load files much faster than say the 128k length.

Using the Centronics interface was a snap. I hooked it up to my TEAL model 270 electronic typewriter/daisy wheel printer via the optional cable. The interface will send standard ASCII codes to the printer using LPRINT, LLIST, some BASIC lines using "stream" channels, or block commands in the supplied word processor software. Since this is a "no-frill" type interface, it doesn't include smart software (like the Aerco interface), that allows you to execute graphics screen dumps, ect. with dot matrix printers. These functions would have to be developed by further programming and software.

I didn't give the RS232 interface a try, since I don't have a compatible peripheral. It should be pointed out that it is a bidirectional type, and baud rate is selectable.

Most prospective buyers would probably be concerned about cassette software compatibility. First of all, take into consideration that this is a Spectrum system. Secondly, commercial programs are usually protected against making back-up copies of any kind (cassette or wafer). You do have the following options:

1. Make wafer copies of Spectrum programs that have the option for making back-ups.
2. Use a "header-reader" type program to help you BREAK and SAVE commercial cassette software for the Spectrum.
3. Any Spectrum program that you can BREAK and SAVE, may be transferred to wafer.
4. Some software for the Timex can be saved on wafer. This includes a few machine code programs, and most all of the BASIC programs. For example, I made a wafer copy of programs from the "Great Game And Graphics Show" by JRC Software.

You may also make copies from wafer to wafer, simply by using the MOVE command. Commercial software is being developed and sold on Rotronics type wafers now. Damco has a list and prices of several titles that they carry in stock.

Much could be said about the Rotronics Wafadrive. More info than we obviously have space in the magazine for. So, I will close, leaving you with a few thoughts to consider. First, the Rotronics is a little faster and lower in price than the A & J model 2000 (if you



were to add an additional drive, printer interface, ect.). The Rotronics is about half the price of a good disk system with only a single drive, but not nearly as fast as floppy disks. It is about the same price as a complete Sinclair Microdrive system, but the Rotronics comes with more features like the built in Centronics interface and free word processor. Also take into consideration that you also receive Spectrum emulation and a Spectrum expansion port...this

will open a whole new world of information for the T/S 2068.

Over all, the features that I liked best were the units small (all-in-one) size, and the ease in which the Rotronics filed and retrieved data. The price should also be within reach of most Timex users budgets.

Good work Rotronics and Damco.

## ZEBRA GRAPHICS TABLET FOR 2068

reviewed by Dennis Jurries

Have you been looking for a way to do screen displays easier than figuring the PLOT and DRAW positions? This may be the way to accomplish the task. The ZEBRA GRAPHICS TABLET is the same one that you may have seen for other computers (also known as the KoalaPad). The system for the Timex/Sinclair 2068 comes with a software program on cassette called "ZPAINT", and a small interface with two RS-232 type (DIN) sockets.

The ZPAINT program allows you to draw pictures using a pen type (narrow one-pixel width) stroke, or a brush type (wide width) stroke. The basic 2068 colors can be used to draw the border and then to "draw" in color. CIRCLE is used by selecting that option and placing the cursor (with the use of the supplied stylus) at the location of the center of the circle, and pressing one of the buttons on top of the Graphics Tablet. Then by placing the cursor at the location of the circumference of the circle and pressing the button a second time, the circle will be drawn automatically. The "pen", and to a certain extent, the "brush" option, put extraneous pixels or "marks" on the screen. However, these can be cleaned up by selecting the white color and redrawing over the marks.

I also had the opportunity to use the "TECH DRAW" and "CIRCUS COLORING BOOK" software programs (supplied as a free bonus with Graphics Tablet purchase). Although the TECH DRAW program only draws in black and white, it has many more features than ZPAINT. There are six separate menus, one for drawing, one for brush selection (sixteen possible types), one for shading (thirtyfive possible patterns), a Text



Actual "doodlings" using the Zebra Graphics Tablet

menu, a Line menu, and an I/O menu (to select printer type, LOAD or SAVE screen). This program is fantastic, but has the erroneous mark problems that ZPAINT has... and must be corrected the same way. See the attached figures. Figure number one is the emblem of the Clackamas County Area Timex/Sinclair User's Group. The next figure (no. 2) shows an attempt (incomplete) at tracing the same emblem in a larger size. No corrections were made. You can see that the fine brush size made more erroneous marks. These marks can be cleaned up, and I believe that with more practice and experience with the Graphics Tablet (and TECH DRAW), great improvements in the figures that are drawn can be made.

The CIRCUS COLORING BOOK software has several screen pictures dealing with the

circus in it. The object is to color in the pictures. This program could keep young children busy for several hours, but outside of that, I can find no practical use for it.

I took TECH DRAW and COLORING BOOK to the last User's Group meeting, and showed two kids aged between 8 and 12 some of the basic commands. Two hours later they were showing me features that I didn't know how to use yet! All in all, the ZEBRA GRAPHICS TABLET and TECH DRAW are excellent, and can be of great help to those who are using a lot of screen displays. It can be fun too.

The Graphics Tablet is available from Zebra Systems, Inc., 78-06 Jamaica Ave., Woodhaven, NY 11421. Phone (718) 296-2385. Price is \$89.95 and with each purchase, a free TECH-DRAW software cassette is included.

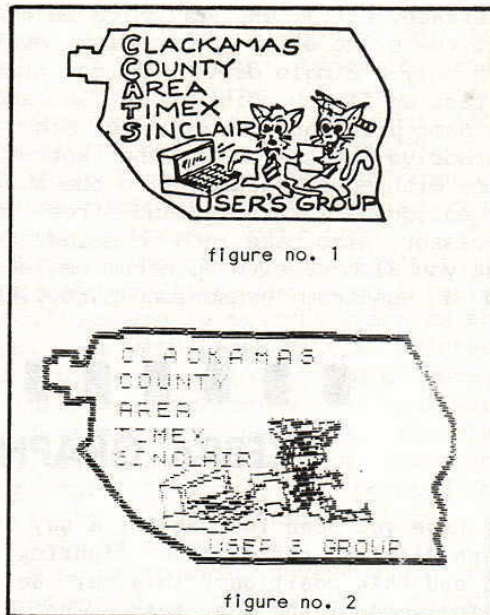

figure no. 1

figure no. 2

## ZEBRA-TALKER

### SPEECH SYNTHESIZER

reviewed by Tim Woods

Speech synthesizers are like a lot of inexpensive computer add-ons...they aren't really essential compared to say a printer. However, they can be a lot of fun, and with a little bit of imagination, could be put to some sort of use.

The ZEBRA-TALKER is a thin module that plugs into the back of the Timex/Sinclair 2068, with a straight-thru connector provided for attachment of other peripherals. The pc board is covered and protected on both sides by thick cardboard. The Zebra-Talker doesn't draw any power from the 2068 because of a small 7.5 DCV transformer that is provided (just what every Timex owner needs--one more transformer). The heart of the unit is the Votrax SC-01 Speech Chip.

This particular type of speech device uses 45 basic speech "sounds" which are called phonemes. The phonemes can be linked together to produce around 1,400 words. More words can be produced by combining various sounds to simulate words. Phonemes are entered by typing in codes. A very nice 20 page dictionary of words and there related codes is provided.

To assist the Zebra-Talker user, is a phoneme editor on cassette software. It is menu-driven, and simplifys entering the codes. If you have made a mistake, or wish to add or change your words, special commands can be used to speed up the chore. I found that the editor was simple, but some-

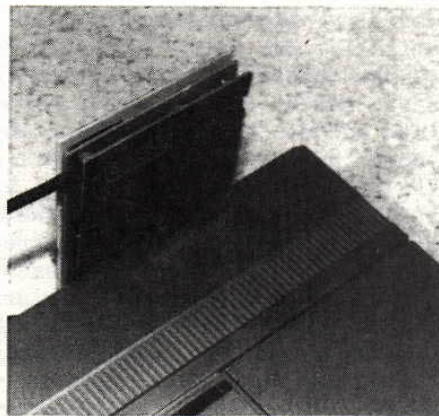

what slow in it's execution. Also on the same tape is a "text-to-speech" MC program that allows the Zebra-Talker to operate through the use of BASIC PRINT statements. The text-to-speech routine has a large vocabulary stored in memory, which is scanned when a word is put into a string or string variable.

A low level output line is included on the Zebra-Taker via a permanently attached 12 inch patch cord. An external amplifier is required to hear the synthesized speech, as no provision is made for a connection to the internal speaker on the 2068. I used a home stereo amplifier and pair of speakers. This gave very excellent results, as the signal from the Zebra-Talker was very clean and crisp. It should be noted that the manufacturer has a companion battery powered amp/speaker combination for \$12.50. It was untested by me, but experience tells me that it must be a low-volume device. I feel that the stereo, or a similar means is very suitable for the home user.

When I first hooked it up, and typed in the simple codes for the words "hello", the voice coming from the loudspeakers was both chilling and funny at the same time. With further use and experimentation, the newness quickly wore off. If you have heard one of those T/I "Speak And Spells" that have been around for educational purposes, you might somehow imagine what the Zebra-Talker sounds like. One feature, that takes away the semi-monotone effect is selectable speech inflection (or level of pitch). Four levels are accessible.

Good documentation is provided. If you think this device is for you, by all means buy one. There are routines shown to include speech in your own programs, so someone out there probably has come up with a good use for the Zebra-Talker. It can be purchased from Zebra Systems, 78-06 Jamaica Ave., Woodhaven, NY 11421, for \$69.95 plus \$3.00 s & h. There is also a version for the T/S 1000 for \$64.95.

## SOFTWARE REVIEWS

### ZIP BASIC COMPILER

reviewed by Michael E. Carver

The resident language in the T/S 2068 is Sinclair BASIC (an altered version of Microsoft BASIC). BASIC is a relatively easy language to learn and thus an easy means of communicating with the microprocessor. The microprocessor can perform approximately 1/2 a million operations per second. Then, why is BASIC so slow? The processor only uses two numbers (1 and 0). Most humans cannot easily communicate or think in pure binary, and thus we need other "languages" in order to talk with our computer. Many microprocessor operations are lost while the computer laboriously translates from BASIC into machine code. Most programs you buy (especially games) are programmed in machine code, bypassing BASIC, and are 100's of times faster than any BASIC program you can write. Enter the compilers...

Compilers translate programs written in BASIC into machine code, eliminating the need to re-translate each time the program is run. ZIP is a program available for the T/S 2068 which can convert BASIC

programs into fast-running machine code. The manual included with ZIP contains benchmark results (run on the Sinclair Spectrum) of BASIC vs. a British version of ZIP, showing speed ratios from 111:1 to 213:1. ZIP is an integer-based compiler (i.e., it only uses whole numbers--no fractions or floating point arithmetic). This compiler is an enhanced version of one published in the British magazine, "Your Spectrum".

As an integer-based compiler, there are many commands which are not available. There are no mathematical functions available beyond +, -, \*, /. You will not be able to compile programs containing any trigonometry functions (TAN, COS, SQR, ect.). Numbers are limited to the range of -32767 to 32767 (though the range of +/- 65535 is allowed if these numbers are not PRINTed, multiplied or divided). There are many other Keywords you may find necessary in some programming which also cannot be compiled. Unfortunately, the manual does not list all of the commands which are not allowed. Trial and error and some common

sense must be your guide. Some of the other commands which are not compilable are: READ, DATA, DEF FN, CIRCLE (nor arcs using DRAW-though straight lines with DRAW is acceptable), SCREEN\$, SAVE, LOAD, BEEP, RND, INKEY\$. Some programmers will find the absence of character strings a major drawback. With proper programming, one can overcome many of these shortcomings (i.e., store character codes in a numerical array and print them with a FOR/NEXT loop using PRINT CHR\$(A(X)). You are limited to 26 single-letter variables and 26 single-dimensioned arrays. Arrays must be DIM'ed with the program listing by constants and cannot be re dimensioned, as their storage area is reserved during compilation. The manual does include routines to simulate INKEY\$, RND, BEEP and STICK. It is also possible to access BASIC or machine code routines from within a compiled program.

The manual states there is room for a "little under 13k" of a BASIC program for compiling, occupying lines 1-4999. In actuality, I found there is only room for about 10.7k, but this left insufficient memory for ZIP to compile. I had to reduce the BASIC program to about 8k before ZIP could completely compile my program. There is approximately 10.5k of memory to store a compiled program and variables. ZIP also includes an "optimizer", which provides for faster running programs. According to the manual, removing this from the package will allow about 2k more of BASIC for compiling. Again I found this to be an overstatement. After removing the optimizer, I only discovered about 1k available.

Programs that are compiled by ZIP run at speeds approaching those of well-written machine code, but actual compiling can be a slow process. Of course, you will have hopefully removed all bugs by testing the program in BASIC and will only have to compile once. Included with ZIP is a demo game (written in BASIC) to be compiled using ZIP. The listing of the demo game is a little over 3k and took about 31 min. to compile. (It appears that ZIP is written entirely in BASIC.) First there is a check of the BASIC itself. Checks are made for correct KEYWORDS and any translation is done before actual compilation begins. There are seven error reports possible during this stage and any illegal KEYWORDS are pointed out, allowing correction before continuing. This process took about 6-3/4 min. to complete. The rest of the time was involved in converting the 3k of

BASIC into approximately 3k of mc. Error reports are also provided during the final stage of compiling.

Aside from the differences in the amounts of memory available, I found that ZIP lived up to its claims. It is fairly easy to use and "user friendly" with its error messages. If the Timex ROM discovers a syntax error while running a compiled program, you will receive a normal Sinclair BASIC error report. It will not report the exact location of the error, only its nature.

ZIP is not a program for a novice BASIC programmer. One who knows how to manipulate a limited BASIC into a code that produces expanded results is best suited as a ZIP user. For those of you who would like to market a program, but feel your knowledge or the time involved in developing machine code is holding you back, the authors of ZIP allow you to sell any programs compiled by ZIP, no fees required...or perhaps you just want to speed up some of those interesting (but slow) BASIC programs in magazines or books...then ZIP may be for you. Before committing yourself to any particular compiler, be sure you can live with its limitations. (Note: There are very few compilers available for the T/S 2068. I know of a few available for the Spectrum, on which can handle strings and multi-length variable names, but not FOR/NEXT loops.)

Though ZIP was not designed as a machine code tutor, I found it can be quite the instructor. One can compile a series of BASIC commands and using a monitor, disassemble the compiled code, and receive some enlightening lessons in writing mc routines.

ZIP comes in a book sized plastic case with one cassette (containing ZIP and a demo game) and documentation. I had no problems in loading my copy on the first attempt. The program was written by Simon N. Goodwin and Jon A. Smith and is available from Knighted Computers, 707 Highland St., Fulton, NY 13069, (phone 315-593-8219), for \$16.50+\$3.00 for s&h (any size order).

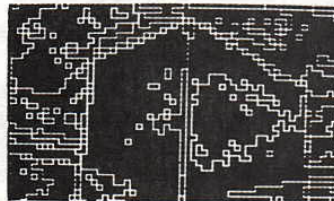

## COUPON MAGIC

|                                                                                                                                                                                                                                                                                                                                                                                                                                                                       |                 |            |
|-----------------------------------------------------------------------------------------------------------------------------------------------------------------------------------------------------------------------------------------------------------------------------------------------------------------------------------------------------------------------------------------------------------------------------------------------------------------------|-----------------|------------|
| MANUFACTURER'S COUPON                                                                                                                                                                                                                                                                                                                                                                                                                                                 | EXPIRES 8/30/85 | <b>25¢</b> |
| <i>Sunshine</i>                                                                                                                                                                                                                                                                                                                                                                                                                                                       |                 |            |
| <b>SAVE 25¢</b> on Hydrox <sup>®</sup><br>Vienna Fingers <sup>®</sup><br>Chips 'N Middles Fudge, <sup>™</sup> Chips 'N Middles<br>Peanut Butter, <sup>™</sup> Chips 'N Middles Mint, <sup>™</sup><br>Oatmeal Peanut <sup>®</sup> or Cup Custard <sup>®</sup>                                                                                                                                                                                                          |                 |            |
| <small>RETAILER: This coupon will be redeemed for face value plus 8¢ handling if used in accordance with the offer stated hereon. Proof of purchases to cover coupons submitted for redemption must be provided on request. Coupon void if taxed, prohibited or restricted by law, or if reproduced. Cash value 1/20 of 1¢. Valid only in U.S.A. Not assignable or transferable. Mail coupon to: Sunshine Biscuits, Inc., P.O. Box 1715, Clinton, Iowa 52734.</small> |                 |            |
| <b>25¢</b>                                                                                                                                                                                                                                                                                                                                                                                                                                                            | 24100           | 107754     |

## 2 PROGRAMS

reviewed by Tom Judd

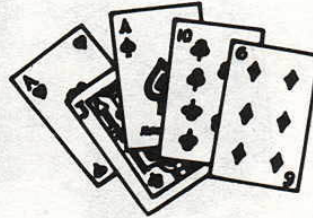

BILL'S COUPON MAGIC is a program written by Bill Erickson of Decatur, GA for the T/S 2068. He sells his own program through HD SOFTWARE, for \$14.95 + \$1.50 for postage. His address is: 1445 Oldfield Road, Decatur, GA 30030.

This program is a lot more than it first appeared. Actually, there are three different functions. The first one is a shopping list that you can enter your items in categories and include the estimated cost of each item. When you are finished, it will give you the estimated amount of money you need to take with you to the store. There is an example provided for easy reference. The second feature is the coupon manager. It is very comprehensive and allows you to store up to 99 coupons with a description apiece. Then you can add coupons to the file or delete old expired ones with the search option. Finally, the third function is an all purpose list manager for anything that suits your fancy.

All of the lists can be sent to the 2040 Printer. You can also save all your data on tape. The program comes with very good documentation.

COUPON MAGIC is an attempt at a useful program. At first, I had visions of sitting down and clipping coupons and tediously entering each one into the computer. This seems like it would be a time consuming chore. I feel this program has a lot more potential being a list manager.

Mr. Erickson has programmed some very nice screen displays for this program, and I really liked the "women with shopping carts" design. All in all this is a nice software package.

THE DEALER'S DEN is a card game program written by Timothy Kessler for the T/S 2068. It is sold exclusively by WMJ DATA SYSTEMS, 4 Butterfly Drive, Hauppauge, New York 11788. It sells for \$19.95 ppd. and there is also a version available for the Commodore 64.

On side one of the cassette tape, is the main program THE DEALER'S DEN. You play four hands of Poker against the dealers one hand. You can throw away unwanted cards once for each hand. You can also select a bet. At the beginning of the program is a table that shows what combination of cards get what value.

I am not exaggerating when I say that THE DEALER'S DEN is genuine fun. Although, I must admit that I am a card game fanatic. When I started playing this one, they couldn't tear me away from the screen!

On side two is another game called DRAW POKER. It is just like the first game, only this time you play only one hand against the dealers hand. It is easier to play, but much harder to win. I preferred the first game.

The graphics for these programs are very good. About the best I have seen for card games on the Sinclair. There is even a little animated card-shuffling sequence while the program is loading. I would recommend that you do use a quality monitor, due to the high resolution of some of the cards and suits are hard to tell apart sometimes.

If you want to pass some time away playing a challenging game of Poker, do yourself a favour and pick up a copy of THE DEALER'S DEN.

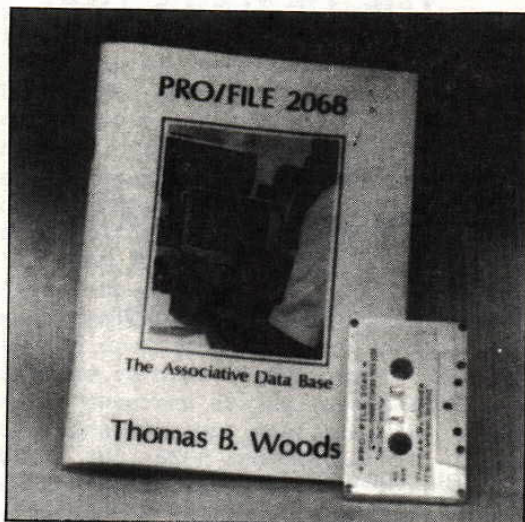

# PRO/FILE 2068

---

---

reviewed by Tim Woods

PRO/FILE 2068 is a very special program, that the author Thomas B. Woods (no relation) has painstakingly put together for owners of the T/S 2068. Supplied with the software on cassette is a real gem of a users manual. It is 143 pages long and makes for some interesting reading.

What does PRO/FILE 2068 do? Tom goes into great detail in the manual describing what it is all about. Basically, it is a filing program or "data base". The possible applications are almost endless. These examples are given: filing mailing lists, business transactions, inventories, ham radio logs, and all kinds of records.

Right away, you will probably notice, that this data base is a little different than some others that were previously available. One that I think everyone has used at one time or other, is Timex's VU-FILE. The way VU-FILE works is by setting up "data fields" that the user specifies when setting up his file. Once the data fields are set, it is a real pain to go back and change or correct the files parameters, without totally redoing the whole thing. PRO/FILE doesn't use "data fields", but instead stores each individual file or record in individual screen displays. To change or delete is very easy with screen displays.

I gave PRO/FILE 2068 a little test drive. I entered 20 of my all time favorite songs as individual files each. Included in the file was the songs title, author, the year it came out, and a few lines from each one. I found that entering the data was easy, but I constantly had to refer to the manual to make sure everything was right. I am sure an avid PRO/FILE user would remember all of the commands...but as a beginner, I stumbled a bit. When all the data had been entered, I began to experiment with some of the multi-word search functions. When I asked for a particular song, it immediately flashed up on the screen.

PRO/FILE has a total capacity of 28,000 bytes! It is compatible with the Timex 2040 Printer or any number of Centronic interfaces and printers.

If you have a special application for PRO/FILE, I am sure information on it would be found in the users manual. It goes into great detail. There is even the program listing of the actual program, that can be altered to suit particular tastes.

PRO/FILE 2068 is an exceptional value at \$29.95. Its file searching and retrieving capabilities are very superior to other data bases that I have seen.

Available from several Timex vendors, and the author, Thomas B. Woods, PO Box 64, Jefferson, NH 03583.

## T/S 2068 GRADE BOOK

reviewed by Dennis Silvestri

Are you a Teacher? Do you use a 2068 computer? Do you have a large number of multiple classes with numerous students? Then the T/S 2068 GRADEBOOK program is for you.

This machine code program allows you to load multiple classes (up to 255 if you use small classes) at the same time with each class handled individually, you can have up to 46 students per class. When you call up a class to get their averages every student will appear on one screen. The averages can be weighted or unweighted and each class can have its own set of weights, which can be changed at anytime. All grades are numeric and each student has a special grade slot for extra credit and another slot for demerits. A missed test is not included in the average unless you wish it to be. Grades can be changed or deleted. Names can be changed or removed. Classes can be alphabetized. New students can be added to any class. Search for and list any student and their entire record on one screen. All classes or individual data can be printed on the Timex 2040 Printer, however, I prefer a full size printer myself.

The T/S 2068 Gradebook program comes with complete documentation and is available for \$19.95 from Robert C. Fischer, 221 Scoggins St., Summerville, GA 30747. This program exceeds every other program I've researched or have used...well done Mr. Fischer.

(Editor's Note: The author informed TIME DESIGNS that a new improved 2068 version 1.4 is ready now for the same price. There is also a T/S 1000 version available.)



## NIGHT GUNNER

reviewed by Tom Judd

NIGHT GUNNER is a game program that was written originally for the British Spectrum, but has been translated to run on a stock T/S 2068. It is on the Digital Integration label (the company that produces the popular Fighter Pilot simulation program), and is sold here by Knighted Computers, 707 Highland St., Fulton, NY 13069, for \$19.95 plus \$3.00 s & h (total order). The basic theme of this game is a WWII air battle.

As long time readers of TIME DESIGNS know, I very much enjoy playing and reviewing games for T/S computers. Night Gunner is an arcade style game in the truest sense of the word. If you were to go down to the nearest arcade video salon, there would be a least half a dozen games that have similar themes and strategies as this one.

You are on a flying mission at night, and as gunner and bomber, you must defend your plane against enemy attack and also destroy ground targets. The two standard screen displays throughout the different missions are straight ahead with moveable gun sights, and flying overhead dropping bombs at high altitudes.

It is fairly easy to score high in this game, especially with joystick in hand. This is probably Night Gunner's biggest plus...joystick control. Playing the gamut of Spectrum software without a joystick, makes a person really appreciate a program with this feature. The response here is quite smooth.

The game also continues for quite a while, even if you aren't shooting like an ace, giving the player ample time to improve skill and points. Two players can also play at once.

While Night Gunner's graphics are adequate, they certainly don't cover anything new. Not like some other English games that this reviewer has seen. But I have a hunch that the author simply wrote this program to be a full-fledge "shoot-em up" arcade game. Nothing more and nothing less. It executes this one goal extremely well.

# THE GREAT GAME AND GRAPHICS SHOW

By Tom Judd

JRC Software has come up with a good idea. Take 17 of your programs and put them all on one tape, and sell your tape to the public. They offer two program tapes in this format, one for the TS 1000/ZX81 called the "Supertape", which contains 42 separate programs! (I will review the "Supertape" in the March/April issue of T.D.M.) And then there is the "Great Games and Graphics Show", with the 17 programs for the TS 2068. An advantage to using the TS 2068 with a software package like this one, is that all of the programs can be loaded in at one time, and then called up by the main menu. All of the games and graphic-type things are on side one of the tape, and on the other side is an unusual text editor/word processor called the "EASY EDITOR". Here is a brief description/review of each one of the short programs on side one of the "Great Games and Graphics Show":

1. Oscilloscope: Very neat! Like a laser light show, with rotating graphics.
2. Stary Sound: Planetarium style stars display, with good sound effect.
3. 3-D City: Good 3-D graphics of tower-like buildings. See the example provided.
4. Snowflakes: Interesting patterns.
5. Flashing Display: O.K., the flashing characters gave me a headache though.
6. Polygons: Back to the title screen. Where are the polygons?
7. Touch Type: I like this one, for people like me who are basic "hunt and peckers". This is one of the better typing/learning games I've seen. Has different levels.
8. Trash Pack (Animation Demo): Simulated Pacman characters without the Pacman game.

9. Lunar Lander Game: Slightly better than standard game, as far as graphics. Crash report flashes too fast.
10. Etchsketch Pad: The old standard for kids. Good use of colors, and has some added features like- saving to tape, inverse, ect.
11. Dodge-em Game: Genuine fun game! Would have been nice to have a running score, but does keep track of score at the end, with previous high scores. Simple... uses only one key, but challenging.
12. 3-D Graph: Three graph planes stacked. Fast and simple.
13. 128 Line Graphics: Also fast, and slightly interesting.
14. Big Star: The old "Spiral-Graph" type graphics.
15. Sine Wave Curves: 3 Sine waves, each with a shadow wave, plus a C major Chord for music at the end.
16. Color Mode 2: Weird, colorful pattern. Interesting.

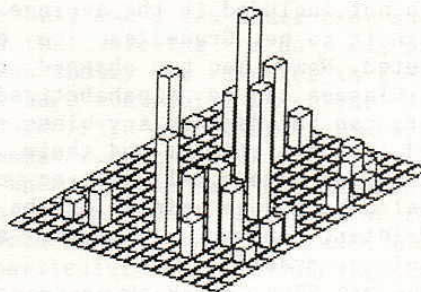

The Easy Editor on side two is written entirely in BASIC. Text is entered in line numbers and REM statements (usually one statement for each paragraph). The editing of text is done by using the cursor arrows and DELETE. You can also have "formatted" text. Text files can either be printed or saved in D\$. The feature I like the best, is the choice of bold printing. It looks great! While Easy Editor is simple, it is not the definition of a fantastic text editor. You might call it the "poor mans word processor".

I liked the "Great Games and Graphics" package, and it is a real bargain for \$24.95. There could have been some better documentation and packaging, but these are just minor complaints. Highly recommended.



# National TS Users Group Directory

## ARIZONA

1st SINCLAIR USERS' GROUP OF PHOENIX  
c/o 9009 West Elm St. #2  
Phoenix, AZ 85037

## CALIFORNIA

BAKERSFIELD TIMEX SINCLAIR USERS GROUP  
2617 Anza Street  
Bakersfield, CA 93305  
(805) 871-7024

EAST BAY Z80 USER GROUP  
654 40th Street  
Richmond, California 94805  
(415) 234-3310

PENINSULA USER GROUP  
263 Gateway #107  
Pacifica, CA 94044  
(415) 359-3198

SILICON VALLEY SINCLAIR TECHNOLOGY USER GROUP  
6675 Clifford Drive  
Cupertino, CA 95014  
(408) 253-3175

SAN DIEGO TIMEX/SINCLAIR USERS GROUP  
809 Oaklawn Ave.  
Chula Vista, CA 92011

SACRAMENTO TIMEX/SINCLAIR USERS GROUP  
3655 Sunset Blvd. #42  
Rocklin, CA 95677

SOUTH BAY COMPUTER CLUB  
2316 Walnut Ave.  
Manhattan Beach, CA 90266

WEST LOS ANGELES SINCLAIR TIMEX GROUP  
PO Box 34545  
Los Angeles, CA 90034

TIMEX SINCLAIR USERS GROUP OF MERCED  
1611 Rose Ave.  
Merced, CA 95340

ZX81/TS1000 USERS GROUP  
PO Box 2411  
Vista, CA 92803

Z80 USERS GROUP  
7962 Center Pkwy  
Sacramento, CA 95823

T/S 1000 USERS GROUP  
PO Box 5703  
Stockton, CA 95204

TIMEX SINCLAIR USERS GROUP  
Hughes Aircraft Company  
Attention: Tony Gomez  
8433 Fallbrook Ave.  
Canoga Park, CA 91304

## COLORADO

TIMEX/SINCLAIR USERS GROUP  
Mile High Chapter  
c/o Jeff Brothers  
914 S. Victor Way  
Aurora, CO 80012  
(303) 892-6666

## CONNECTICUT

NEW HAVEN SINCLAIR STUDY GROUP  
16 Lewis Street  
New Haven, CT 06501

SINCLAIR TIMEX USERS GROUP  
1070 S. Colony Road  
Wallingford, CT 06492

## FLORIDA

GAINESVILLE TIMEX USERS GROUP  
3708 Newberry Road  
Gainesville, FL 32607

TAMPA AND SUNCOAST BAY AREA  
MICROCOMPUTER USERS GROUP, INC.  
PO Box 644  
Safety Harbor, FL 33572

SINCLAIR TIMEX SOUTHEAST REGION CLUB  
869 Levitt Parkway  
Rockledge, FL 32955

N.E. FLORIDA TIMEX/SINCLAIR USERS GROUP  
1707 King Street  
Jacksonville, FL 32204

SOUTH FLORIDA ZX USERS GROUP  
PO Box 057381  
West Palm Beach, FL 33405

ZX TIMEX GROUP  
950 Cynthia Drive  
Titusville, FL 32780

TIMEX SINCLAIR COMPUTER CLUB  
808 East Anderson Street  
Orlando, FL 32801

N.W. FLORIDA 2068 TIMEX SINCLAIR USERS  
402 Pine Terrace Circle  
Milton, FL 32570

LEESBURG AREA (CENTRAL FLORIDA)  
TIMEX SINCLAIR USER CLUB  
c/o Warren Fricke  
225A Highland Drive, MFL  
Leesburg, FL 32788  
(904) 589-2729

## GEORGIA

TIMEX USER GROUP OF MARIETTA  
3105 Mary Drive N.E.  
Marietta, GA 30066

ATLANTA TIMEX USERS GROUP  
8286 Canyon Forge Drive  
Riverdale, GA 30274

## ILLINOIS

CIRCLE CHESS COMPUTER CLUB  
PO Box 63  
Des Plaines, IL 60017

SINCLAIR USERS NETWORK  
2170 Oak Brook Circle  
Palatine, IL 60067

CHICAGO AREA TIMEX SINCLAIR USERS GROUP  
c/o Mark Biery  
741 Dunbar  
Beecher, IL 60401  
(312) 946-6892

## INDIANA

INDIANA SINCLAIR TIMEX USERS GROUP  
513 East Main Street  
Peru, IN 46970  
(317) 473-4885

TIMEX 1000 NATIONAL SOFTWARE EXCHANGE  
c/o Greg Gunthrop  
RR2 Box 162  
LaGrange, IN 46761

## IOWA

TIMEX SINCLAIR USERS GROUP  
c/o Donald Lambert  
3310 Clover Drive S.W.  
Cedar Rapids, IA 52404

## KANSAS

KANSAS AREA TIMEX SINCLAIR USERS GROUP  
124 W. 10th  
Andover, KS 67002

## KENTUCKY

PORTSMOUTH TIMEX/SINCLAIR USERS GROUP  
c/o John Marion  
HC 63 Box 650  
Greenup, KY 41144  
(606) 473-6791

## MARYLAND

CAPITOL AREA TIMEX/SINCLAIR USERS GROUP  
c/o Jules Gesang  
PO Box 725  
Bladensburg, MD 20710

WESTINGHOUSE ZX81 USERS CLUB  
Attention: Jack Fogarty  
Mail Stop 3525  
WESTINGHOUSE  
PO Box 1521  
Baltimore, MD 21203

## MASSACHUSETTS

TIMEX SINCLAIR SPECIAL INTEREST GROUP  
THE BOSTON COMPUTER SOCIETY  
One Center Plaza  
Boston, MA 02108

BOSTON AREA TIMEX/SINCLAIR USERS GROUP  
c/o Rick Heiser  
4 Ox Road  
Billerica, MA 01821

MITRE BEDFORD TIMEX/SINCLAIR COMPUTER CLUB  
MITRE CORPORATION  
Attention: John Kemeny  
Bedford, MA 01730

## MICHIGAN

S.E. MICHIGAN COMPUTER ORGANIZATION  
PO Box 02426  
Detroit, MI 48202

SAF USER GROUP  
c/o Robert Dodge  
PO Box 313  
Mason, MI 48858

## MISSOURI

KANSAS CITY TIMEX SINCLAIR USERS GROUP  
4701 N.W. Linden Road  
Kansas City, MO 64151

JOPLIN SINCLAIR USERS GROUP  
PO Box 2221  
Joplin, MO 64803

## NEBRASKA

SINCLAIR USERS NETWORK  
4903 Walder  
Lincoln, NE 68504

OMAHA TIMEX/SINCLAIR USERS GROUP  
c/o Dan Hargens  
2104 South 35th Ave.  
Omaha, NE 68105

## NEVADA

TIMEX USERS GROUP OF LAS VEGAS  
c/o Sven J Nilsson  
2405 Howard Drive  
Las Vegas, NV 89104

## NEW JERSEY

AERCO DISK USERS GROUP  
c/o R. Burke Mawby  
PO Box 89  
Matawan, NJ 07747

MORRIS COUNTY TIMEX USERS GROUP  
c/o Larry Spencer  
6 Forest Court  
Morris Plains, NJ 07950

## NEW MEXICO

TIMEX/SINCLAIR AMATEUR RADIO USERS GROUP  
c/o Alex Burr K5XY  
2025 O'Donnell  
Las Cruces, NM 88001  
(505) 646-5194

## NEW YORK

LONG ISLAND SINCLAIR TIMEX GROUP  
PO Box 438  
Centerport, NY 11721

SINCLAIR COMPUTER USERS SOCIETY  
PO Box 523  
Owego, NY 13827

NEW YORK TIMEX SINCLAIR ENTHUSIASTS  
c/o Stoney McMurray  
473 Westminister Road  
Brooklyn, NY 11218  
(718) 469-5948

TIMEX SINCLAIR USERS GROUP  
c/o Arthur Schaefer  
112 Wendel Ave.  
Buffalo, NY 14223

PC USERS GROUP OF NEW YORK  
Box 560 Wall Street  
New York, NY 10005

TIMEX SINCLAIR USER CLUB  
c/o Richard Norek  
188 St. Felix Ave.  
Cheektowaga, NY 14227

## NORTH CAROLINA

TRIANGLE SINCLAIR USERS GROUP  
c/o Doug Dewey  
206 James St.  
Carrboro, NC 27510

TIMEX USERS GROUP  
Rt 3 Box 641  
Robinsville, NC 28771

## OHIO

TIMEX PORTSMOUTH, OHIO REGION USER GROUP  
2002 Summit Street  
Portsmouth, OH 45662

GREATER CLEVELAND AREA SINCLAIR USERS GROUP  
c/o James Dupuy  
6514 Bradley Ave (down)  
Parma, OH 44129

DAYTON MICROCOMPUTER ASSOCIATION  
2629 Ridge Ave.  
Dayton, OH 45414

TIMEX SINCLAIR USERS GROUP OF CINCINNATI  
c/o Rick Johnson  
11 Funston Lane  
Cincinnati, OH 45218

TIMEX/SINCLAIR USERS GROUP  
4255 S. Hamilton  
Columbus, Ohio

## OKLAHOMA

TIMEX SINCLAIR USERS GROUP  
c/o Bill Casebeer  
PO Box 372  
Cologah, OK 74053

## OREGON

CLACKAMAS COUNTY AREA TIMEX/SINCLAIR USERS  
1419 1/2 7th Street  
Oregon City, OR 97045

PORTLAND AREA TIMEX SINCLAIR USERS GROUP  
c/o Michael Carver  
1016 Tillamook  
Portland, OR 97212

## PENNSYLVANIA

CENTRAL PA TIMEX/SINCLAIR USERS GROUP  
c/o Bill Russell  
RD 1 Box 539  
Centre Hall, PA 16828

HARRISBURG AREA TIMEX SINCLAIR USERS GROUP  
c/o Dave Bennett  
329 Walton Street (Rear)  
Lemoyne, PA 17043

TIMEX SINCLAIR USERS GROUP  
c/o Darryl Butler  
PO Box 53490  
Philadelphia, PA 19105

## TENNESSEE

TIMEX USERS GROUP  
1501-B Compton Ave.  
Nashville, TN 37212

SINCLAIR NETWORK  
4420 Alabama Ave. #2  
Chattanooga, TN 37409

## TEXAS

TIMEX/SINCLAIR USERS GROUP OF FORT WORTH  
c/o David Baulch  
4424 Geddes Ave  
Fort Worth, TX 76107

TIMEX/SINCLAIR USERS GROUP  
c/o Jeo Jenkins  
3100 Mockingbird  
Amarillo, TX 79109

DALLAS TIMEX SINCLAIR USER GROUP  
2624 E. Park Blvd.  
Plano, TX 75074

HOUSTON TIMEX/SINCLAIR USERS GROUP  
13327 Rain Lilly Lane  
Houston, TX 77083

SAN ANTONIO TIMEX/SINCLAIR USER GROUP  
c/o Jim Houston  
414 W. Elsmere  
San Antonio, TX 78212

## VIRGINIA

RICHMOND AREA TIMEX/SINCLAIR USERS GROUP  
c/o Walter Styles  
4201 Old Hundred Rd.  
PO Box 325  
Chester, VA 23831

HAMPTON ROADS TIMEX/SINCLAIR USERS GROUP  
c/o David Alford  
112 Kohler Cres.  
Newport News, VA 23606

SOUTHERN VA TIMEX USERS NETWORK  
Rt 1 Box 21  
Glade Hill, VA 24092

ROANOKE AREA TIMEX USERS GROUP  
PO Box 1165  
Roanoke, VA 24011

## WASHINGTON

SEATTLE AREA TIMEX USERS GROUP  
Apt. 350  
3501-88 Ave. S.E.  
Mercer Island, WA 98040  
(206) 236-0470

## WISCONSIN

SINCLAIR MILWAUKEE USERS GROUP  
PO Box 101  
Butler, WI 53007

## DISTRICT OF COLUMBIA

WASHINGTON AREA USERS GROUP  
PO Box 6239  
Washington, DC 20015

CANADA

OKANAGAN QL USERS GROUP  
c/o W.M. Johnston  
Site 41 E. 17 R.R.#3  
Penticton, B.C.  
V2A 7KA

CALGARY TIMEX SINCLAIR USERS GROUP  
Box 201 Stn. G  
Calgary, Alberta  
T3A 2G2

WATERLOO/WELLINGTON TIMEX/SINCLAIR USER'S GROUP  
645 (B) Silverbirch Road  
Waterloo, Ontario  
N2L 4R4

TIMEX-SINCLAIR USER GROUP  
1545 Alta Vista Drive  
Apt. 1402  
Ottawa, Ontario  
K1G 3P4

TIMEX/SINCLAIR USERS GROUP OF VANCOUVER  
#108 1205 Johnson Street  
Coquitlam, B.C.  
V3B 6E6

VICTORIA SYNC ASSOCIATION  
942 Cloverdale Ave  
Victoria, B.C.  
V8X 2T6

TORONTO TIMEX/SINCLAIR USERS CLUB  
PO Box 7274 Stn. A  
Toronto, Ontario  
M5W 1X9

VIMONT LAVAL USERS  
125 DePiemont 2  
Vimont, Laval  
H7M 1B7

ZX81 USER CLUB  
95 Wayne Ave  
Scarborough, Ontario  
M1R 1Y6

ADVENTURERS GROUP  
c/o Douglas Jeffery  
Larch Rd. RR#1  
Telkwa, B.C.  
V0J 2X0

MEXICO

MEXICAN TIMEX/SINCLAIR USER GROUP  
c/o M. Adriana Rodriguez Maldonado  
Tla'loc #21, Col. Tlaxpana  
C.P. 11370  
Mexico, D.F.



# TIMEX



## Resource Guide

The following is a list of companies who have advertised in previous issues of TDM, and who are currently providing after-market support for Timex Sinclair computers. It is not necessarily a complete list of all known suppliers, but only those who have appeared in our pages. Feel free to write (or call) for their brochures and catalogs...see what they have to offer; you may be pleasantly surprised. Please mention that you saw their listing in this publication. This listing is in no particular order, and is subject to change.

**WEYMIL CORPORATION**  
BOX 5904  
BELLINGHAM, WA 98227-5904

**RUSSELL ELECTRONICS**  
RD 1 Box 539, Centre Hall, PA 16828  
814-364-1325, 10-7 EST Mon-Sat

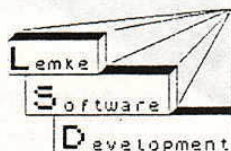

**S D Lemke**  
Lemke Software Development  
2144 White Oak  
Wichita, KS 67207

**KNIGHTED COMPUTERS**  
707 Highland St.  
Fulton, NY 13069  
(315)-593-8219

**WMJ DATA SYSTEMS**  
4 BUTTERFLY DRIVE  
HAUPPAUGE, NEW YORK 11788  
(516)543-5252 (Anytime)

**FOOTE SOFTWARE**  
P. O. Box 14655 — Gainesville, FL 32604  
904/462-1086 (6 pm - 9 pm EDT)

**MARKEL ENTERPRISES**  
Post Office Box 2392  
Secaucus, New Jersey 07094-0992  
(718) 627-1293

**curry  
computer**

P.O. Box 5607  
Glendale, Arizona 85312-5607, U.S.A.  
Telephone: 1-602-978-2902

HUNTER  
1630 FOREST HILLS DRIVE  
OKEMOS, MICHIGAN 48864

## ZEBRA SYSTEMS, INC.

78-06 Jamaica Avenue, Woodhaven NY 11421

(718) 296-2385

## SHARP'S INC.

Rt. 10 Box 459  
Mechanicsville, VA 23111  
(804) 746-1664 or 730-9697

## RMG ENTERPRISES

1419 1/2 7th STREET  
OREGON CITY, OR 97045  
(503) 655-7484

## BEAVER COMPUTER PRODUCTS

999 MUNROE AVENUE, WINNIPEG, MANITOBA, R2K 1J4

LARKEN ELECTRONICS  
RR#2 NAVAN ONTARIO  
CANADA K4B-1H9

## BYTE-BACK

INC.  
RT.4 BOX 54, LEESVILLE, SC 29070

## 21<sup>st</sup> CENTURY ELECTRONICS

YOUR TIMEX and MEMOTECH CENTER

P.O. BOX 5037 GUTTENBERG, NJ  
07043

AN-TO PRODUCTIONS  
9009 W. Elm Street, #2  
Phoenix, Arizona 85037



## pleasantrees PROGRAMMING

P.O. Box 2034 Mesa, AZ 85204



**E. Arthur Brown Company**  
3404 Pawnee Drive, Alexandria, MN 56308



Box 18093 Austin TX 78760  
Ph (512) 451-5874



Basically Programming  
2528 W. Olive Avenue  
Fullerton, CA 92633

BUDGET ROBOTICS & COMPUTING  
BOX 18616, TUCSON, ARIZONA 85731

Fred Nachbaur  
SILICON MOUNTAIN COMPUTERS  
C-12, Mtn. Stn. Group Box  
Nelson, BC V1L 5P1  
CANADA

**A<sup>+</sup> Computer Response**

69-B Island St. • Keene, N.H. 03431 • (603) 357-1800

**C. W. Associates**

419 N. Johnson Street  
Ada, Ohio 45810

Bill Jones, Gulf Micro  
1317 Stratford Ave,  
Panama City, FL 32404

QUANTUM COMPUTING, Box 1280,  
Dover, N.J. 07801 CALL: (201)  
328-8846 The QLINE - ANYTIME 24  
HOURS!

VARIETY SALES  
325 WEST JERSEY STREET #2D  
ELIZABETH, NJ 07202  
PHONE: 201-527-0535

# COMPUTER SHOPPER™

PO BOX 1419  
TITUSVILLE FL 32781-9988

A.F.R. SOFTWARE  
1605 Pennsylvania Avenue, No. 204  
Miami Beach, Florida 33139

(305) 531-6464

Chia-Chi Chao  
73 Sullivan Drive  
Moraga, Ca. 94556



CTM Magazine  
1704 Sam Drive  
Birmingham, AL 35235

## America's BEST Timex/Sinclair Magazine

### TIME DESIGNS MAGAZINE

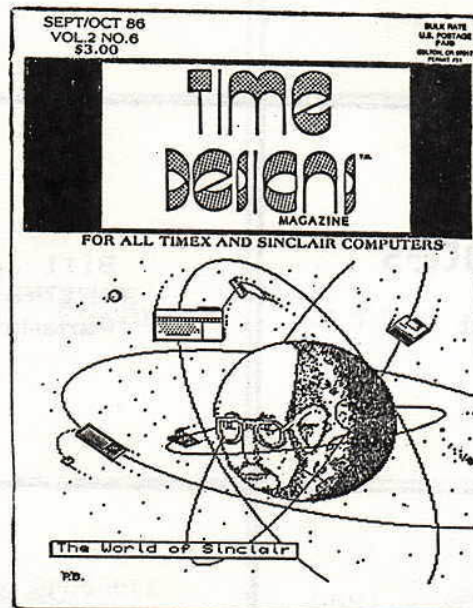

## TIME DESIGNS MAGAZINE COMPANY

29722 Hult Rd., Colton, OR 97017 (503) 824-2658